

# Walk-In Type Temperature (& Humidity) Chamber



# Flexible variation to fit just what you need with ultimate performance, reliability, and energy-efficiency.

Walk-in Type Temperature (& Humidity) Chambers have already proved its eligibility across the fields.

ESPEC now brings you the NEW Walk-in Type Temperature (& Humidity) Chamber, with a selection of chamber size and air conditioning capacity.

Its flexible and user-friendly technology will cover whatever requirements for building your ideal chamber.

Experience its upgraded performance and reliability, automated operation, and significantly reduced power consumption.

EBL - 3HP





Larger viewing window is optional.

# Eco-friendly

**Saving energy**      **major reduction in power consumption and power equipment capacity**

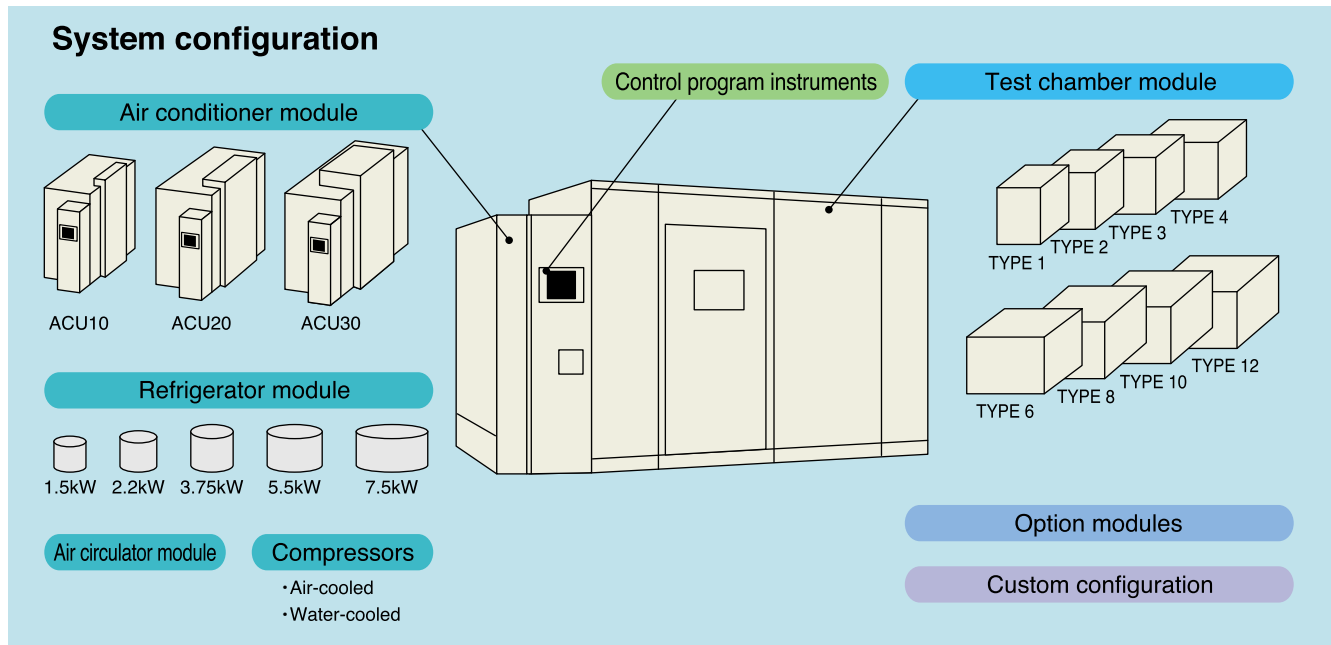

## CUSTOM-MADE SPECIFICATIONS

High temperature specification	Highest adjustable temperature may be raised to + 120 by changing the insulation method.
Cryogenic specification	Equipped with a cascade refrigeration system for lowest temperature measurements below even - 40
Low-humidity specifications	Low-temperature/low-humidity control range may be expanded by using dry dehumidifier (ex. + 5 /5%rh)
Support for low-temperature, high-load conditions	The refrigeration system is converted to a cascade refrigeration system to support high heat-load conditions at low temperatures.
Custom shape and size	Chamber with a capacity greater than Type 12 (standard specification) may be ordered. Adjustable height.
Shield installation	Shielding to eliminate electromagnetic noise that can be generated outside or inside the chamber (radio wave insulation).
Chamber without floor panel	The floor of the structure may be applied as the floor of the chamber to allow heavy objects.
Remodel an existing room into a chamber	A room is made over into a temperature/humidity chamber, which is given heat insulation and water proofing on the walls, ceiling and floor.
Outdoor air cooling specification	Refrigerator may be installed outside the building.
Low VOC specification	VOC concentration measurement

### ● Fit for required performance

In order to meet heat load and temperature heat-up/pull-down time requirements, we are ready with variations of air conditioners.

### ● Optimum air conditioners save energy and space

By combining air circulator, heater, humidifier, and refrigerator, an optimum air conditioning unit can be configured for specific chamber capacity and heat load requirements.

### ● Indoor air-cooling options (EBL, EBR, EBU, EBUU)

We offer a comprehensive range of indoor air-cooling options. Initial costs can be kept low since no water-cooling equipment is required.

### ● Custom-made chambers

Your chambers may be made to order to satisfy any test requirements.

# Eco-friendly

## ● An expanded PID system allows drastic energy saving

The chamber incorporates an electronic expansion valve which adjusts flow of refrigerant, and a newly-developed expanded PID system which automatically controls output of the refrigerator and heater. Compared with the previous model, power is reduced by a maximum of 68% during temperature operation, and 50% during temperature & humidity operation at power-saving mode.

## ● Chamber is automatically controlled by setting the temperature & humidity

By just setting the temperature and humidity conditions, operation is automatically controlled such that maximum power is used to achieve the set condition and minimum power once it is achieved. Optimum control is maintained even after opening and closing of the door and changes of heat load.

## ● Reducing power equipment capacity with cross-output control

Cross-output control lowers the maximum current used during operation, minimizing required power equipment capacity. (EBE, EBL, EBR)

ex: Maximum current and power equipment capacity are reduced by approximately 21% and 23% each for EBL-3.

## ● Select from two modes

Select the "Normal Mode" for frequently changing temperature and humidity conditions and flexible adjustments to rapid changes in the heat load generated by the sample. The "Power Saving Mode" keeps power consumption down for constant operation. Select either mode depending on testing circumstances.

## ● Ozone layer protection

The HFC refrigerant used is completely safe for the ozone layer. (HFC404a or HFC404a + HFC23)

## ● Comparison of power consumption (with EBL-6)

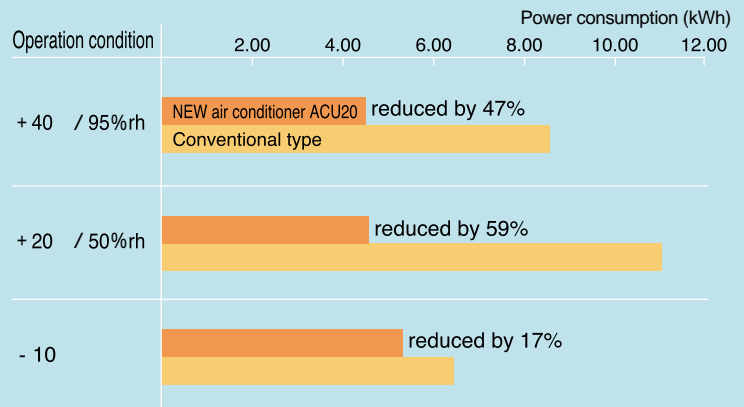

\*Sample figures are shown above.

## Overall control is maintained for the entire unit. The example shown here is chamber with two refrigerators.

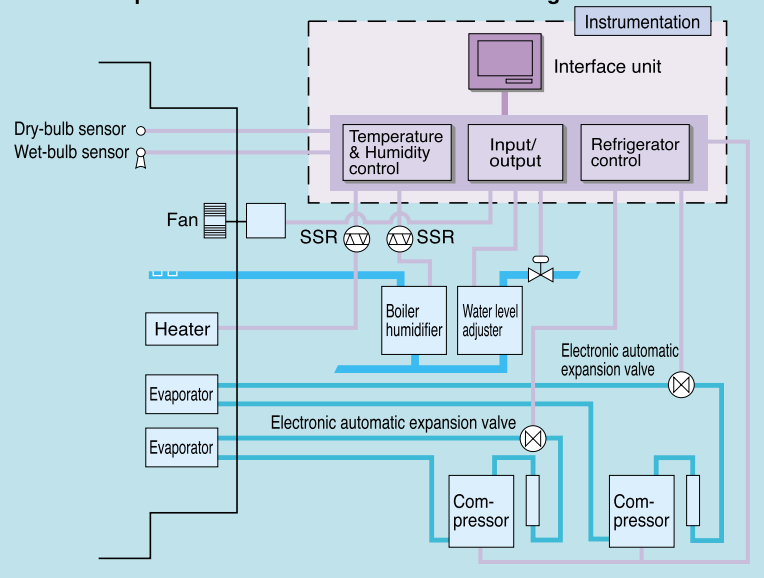

## Temperature & humidity control range

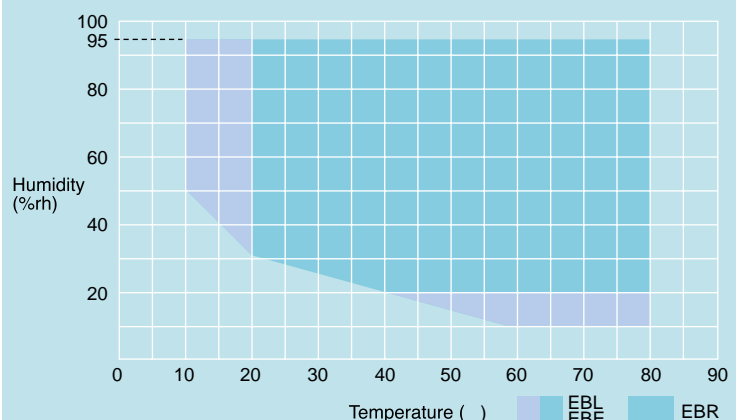

## A user-friendly approach to ensure ease of use



Chamber interior

- **Fully-flush chamber interior**

The air conditioning room of the chamber is fully flush. This maximizes the use of the chamber space.

- **Viewing window with automatic defogging**

The heater automatically activates according to the preset temperature to defog the viewing window on the door. A larger viewing window is also available as an option.

- **Increased reliability**

Continuous and smooth performance is allowed by increased reliability of the chamber and its components, with our newly-incorporated boiler humidification method, graphical display of trouble shooting advice, and backup function for assisting in case of failure.

- **Maintaining operation despite malfunction**

Even when part of the unit malfunction, backup functions can compensate for the failure and keep the unit under operation, thus eliminating the need to suspend testing. For example, if the humidifier fails, operation is switched to temperature operation.

- **Troubleshooting instructions displayed on screen**  
**Alarm message display**

When a malfunction occurs, the cause of the problem and appropriate troubleshooting are immediately displayed.

- **Paperless Recording (optional)**

The paperless recorder makes it easy record the temperatures of different components, such as the chamber temperature, on a memory card (Compact Flash).

Malfunction recovery processing screen



Malfunction description

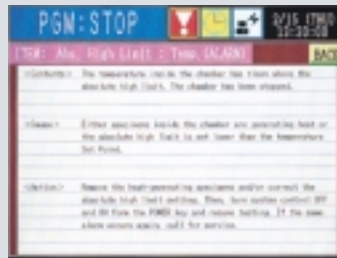

Paperless recorder (optional) \*Sample photo

## Variety of functions to provide confident test data results

### ● Defrosting system with a cycle timer

Non-frost operation is standard-equipped with the newly incorporated refrigeration technology.

During operation within the frosting range, the system automatically defrosts the evaporator by just setting the timer.

### ● Boiler humidification method reduces maintenance effort

The humidifier installed outside of the chamber incorporates a self-cleaning water circulation system, thereby making it difficult for impurities to collect. The heater will not be affected with small quantity of impurities, thereby reducing frequent cleaning work. Cleaning instruction will be displayed on the instrumentation screen when necessary. It can then be carried out from outside the chamber.

### ● Supports a centralized control system for environmental testing (CMS-J30 sold separately)

This is a fully customizable system that provides centralized control, centralized monitoring, remote operation and specimen data management of ESPEC products (up to 32 units of which 16 are dedicated to centralized monitoring) by the use of a PC. Windows® 2000 software provides easy-to-use data processing functions, such as program editing.

### ● Environmental testing centralized control software ERC-100M/200M/300M (sold separately)

The application software allows centralized monitoring, control, and remote operation of up to 16 ESPEC chambers. (monitoring only for 300M) You can drastically save time while your PC collects data for analysis and graphing.

\*Software: English, Chinese (in simplified characters), Japanese (English and Japanese only for ERC-300M)

\*Chambers must be equipped with a E-BUS port when using ERC-100M/300M, and RS-485 port when using 200M.

\*For further inquiries, please contact your nearest ESPEC office.

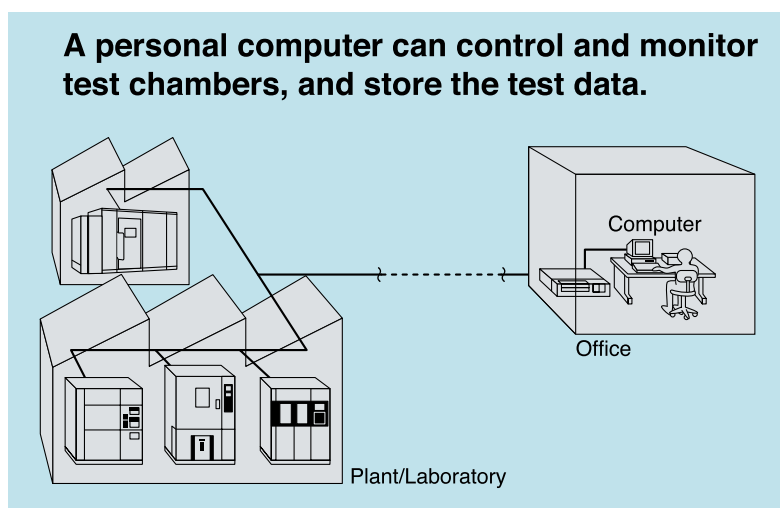
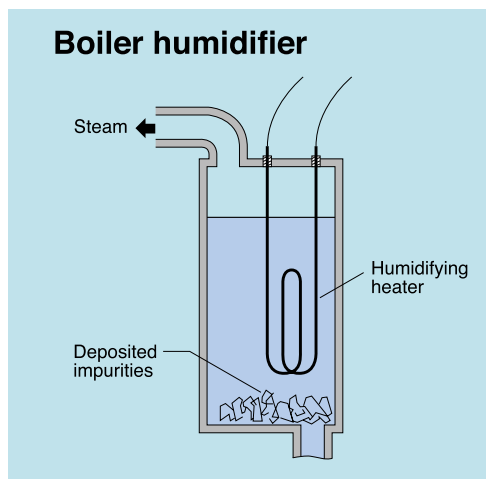
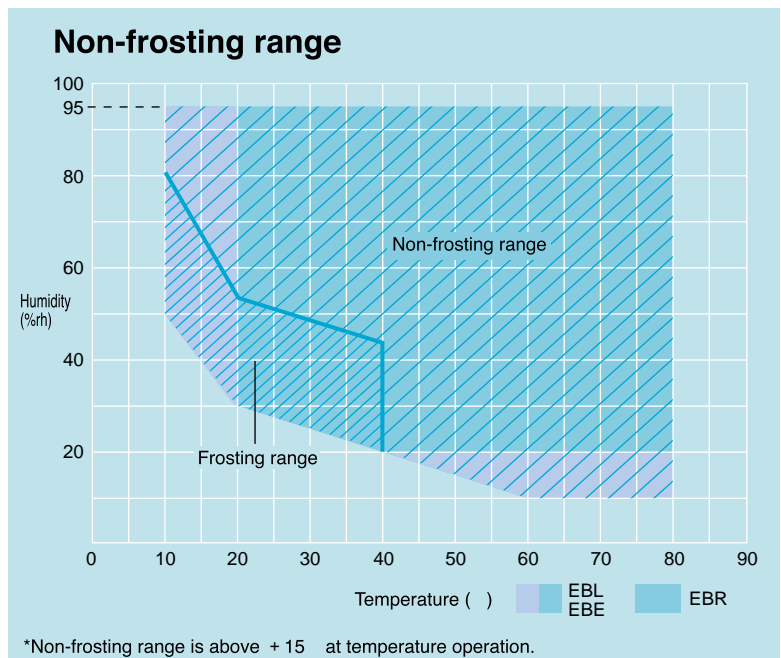

# Control operation

## A 6.5-inch TFT color LCD screen and a touch-key input method improve visual recognition and ease of operation



### Temp/humid program indicator controller

Operation mode	Program operation, Constant operation
Display	Color TFT LCD (6.5 inch)
Setting	Touch panel method
Program capacity	RAM pattern: 20 program patterns • 99 steps/ pattern • Patterns can be chained Total: 1,980 steps
Setting and indication ranges	Temp: temperature range lower limit - 5 to upper limit + 5 Humidity: 0 to 100%rh Time: 0 to 999 hours 59 min
Setting and indication resolution	Temp: 0.1 Humidity: 1%rh Time: 1 min
Auxiliary functions	<ul style="list-style-type: none"> <li>• Refrigerator capacity automatic control (response to heat load)</li> <li>• Operation mode selection (standard mode, power-saving mode)</li> <li>• Timer (automatic start and stop)</li> <li>• Backup operation</li> <li>• Power failure recovery selection</li> <li>• Alarm indication</li> <li>• Self-diagnosis</li> <li>• Trend graph display</li> </ul>

### ● Enables a variety of program settings

The program memory is capable of storing 20 patterns (99 steps per pattern) for a total of 1,980 steps. Time for each step can be set in 1-minute increments up to a total of 999 hours and 59 minutes. Steps can be inserted, copied and deleted. Patterns can be confirmed on the screen, and may start operation from intermediate steps.

### ● Alarm function

If malfunction does occur, the details, date and time of occurrence are displayed on the alarm screen. Also the cause and recovery procedures are instructed on the next screen.

### ● Trend graph display

This display shows past operation history in a graph together with the temperature and humidity operation status.

### ● Timer function

Standard timer function enables automatic start and stop of the chamber. The timer allows setting of the month, date, day of week, and time.

### ● Recovering from power failure

Select from "power off", "resume operation", and "ambient temperature recovery". You may also set the backup functions to continue operation even during failure.

### ● Main alarm displayed on the panel

- Input burnout detection
- Upper/lower temperature (& humidity) alarm
- Independent temperature overheat
- Air circulator failure
- Refrigeration current failure
- Condenser cooling water failure
- Refrigeration surface temperature failure
- Refrigeration high pressure failure
- Heater failure
- Humidifier failure
- Humidifier water supply failure
- Local overheat failure
- Humidifier boil-dry failure
- Humidifier water drain failure

# Control operation

Panel display

## ● Program monitor



## ● Programming

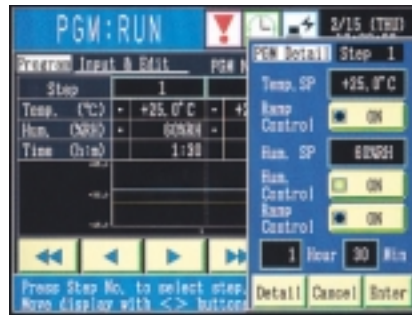

## ● Energy saving mode setting



## ● Automatic operation setting



## ● Malfunction recovery process setting



## ● Timer setup

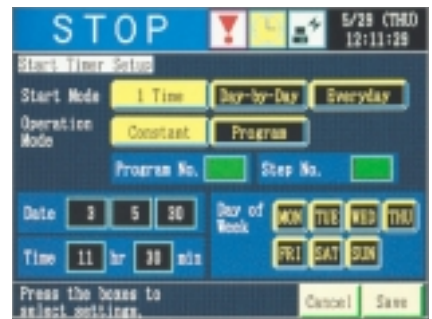

## ● Trend graph



## ● Alarm history

No.	Type	Alarm	When Occurred
10	NEW	OUTPUT CONTACT TRIPBLE	5/29 12:11:29
9	NEW	EMERGENCY STOP SWITCH STOP	5/29 12:11:29
8	NEW	OPERATING SWITCH SWITCH STOP	5/29 12:11:29
7	NEW	INTERMITTING	5/29 12:11:29
6	NEW	MAN-SET AL-400	5/29 12:11:29
5	NEW	FOR CONDENSER FILLING	5/29 12:11:29
4	NEW	PROTECTED FILLING	5/29 12:11:29
3	NEW	DEF. WORK	5/29 12:11:29
2	NEW	DEFROSTER PROBLE	5/29 12:11:29
1	NEW	REFRIG.-1.00 OVERCURRENT	5/29 12:11:29

## ● Alarm description

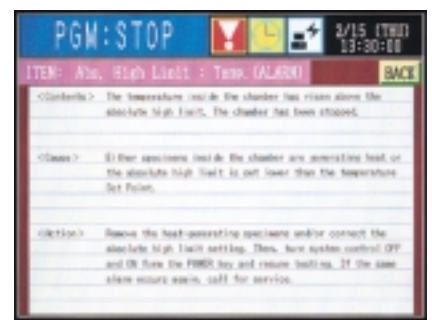

## ● Service guide

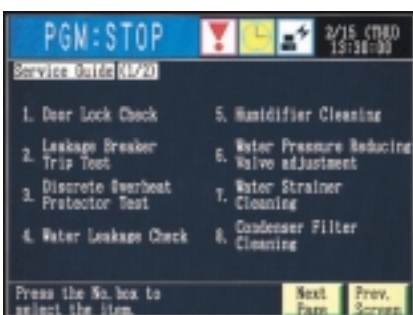

## Basic series

Model	Temperature range ( °C )	Humidity range (%rh)	Inside capacity (floor area)	Instru- mentation	
Temperature and Humidity Chamber	EBE	- 40 ~ + 80	10 ~ 95	Program Instrumentation	
	EBL	- 30 ~ + 80	10 ~ 95		
	EBR	- 10 ~ + 80	20 ~ 95		
	Temperature Chamber	EBF	- 40 ~ + 80		TYPE 1: 4.2m <sup>3</sup> ( 2.0m <sup>2</sup> ) TYPE 2: 8.1m <sup>3</sup> ( 3.9m <sup>2</sup> ) TYPE 3: 12.5m <sup>3</sup> ( 5.9m <sup>2</sup> ) TYPE 4: 16.8m <sup>3</sup> ( 8.0m <sup>2</sup> ) TYPE 6: 25.8m <sup>3</sup> (12.3m <sup>2</sup> ) TYPE 8: 34.8m <sup>3</sup> (16.6m <sup>2</sup> ) TYPE 10: 43.8m <sup>3</sup> (20.8m <sup>2</sup> ) TYPE 12: 52.7m <sup>3</sup> (25.1m <sup>2</sup> )
		EBU	- 30 ~ + 80		
		EBUU	- 10 ~ + 80		

## Standard configuration

### Air conditioner module

unit: mm (inch)

ACU10

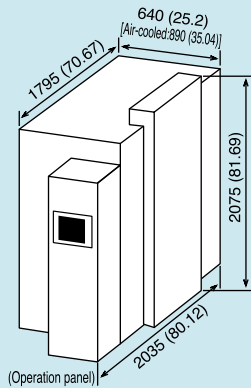

ACU20

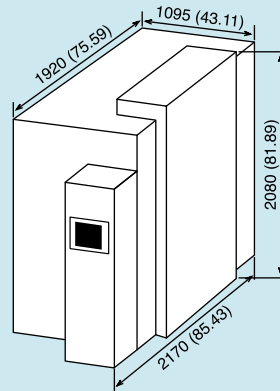

ACU30

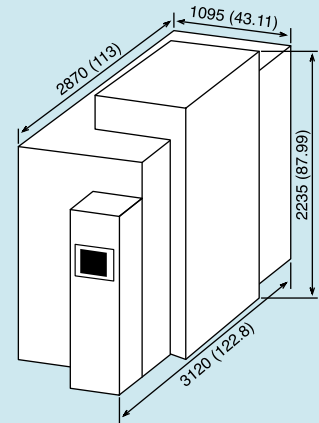

\*Position of operation panel depends on layout.

\*For air-cooled type ACU10, width of air-conditioner is 250mm (9.84 inch) longer.

### Test chamber module (Inside dimensions)

unit: mm (inch)

TYPE 1

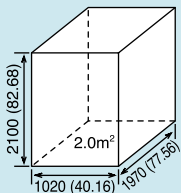

Outside dimensions  
W1790 x H2305 x D2100  
(W70.47 x H90.75 x D82.68)

TYPE 2

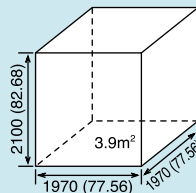

Outside dimensions  
W2740 x H2305 x D2100  
(W107.9 x H90.75 x D82.68)

TYPE 3

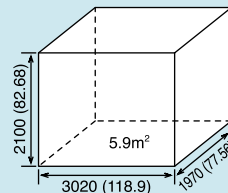

Outside dimensions  
W3790 x H2305 x D2100  
(W149.2 x H90.75 x D82.68)

TYPE 4

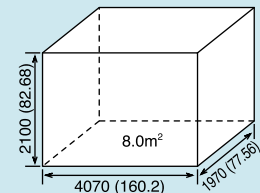

Outside dimensions  
W4840 x H2305 x D2100  
(W190.6 x H90.75 x D82.68)

TYPE 6

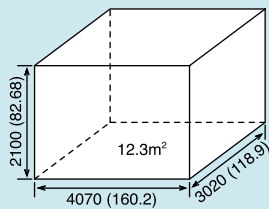

Outside dimensions  
W5295 x H2405 x D3150  
(W208.5 x H94.69 x D124)

TYPE 8

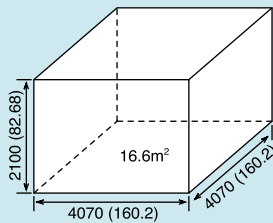

Outside dimensions  
W5295 x H2405 x D4200  
(W208.5 x H94.69 x D165.4)

TYPE 10

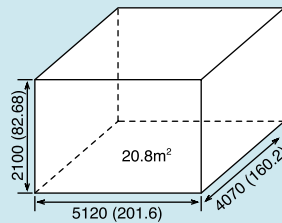

Outside dimensions  
W6345 x H2405 x D4200  
(W249.8 x H94.69 x D165.4)

TYPE 12

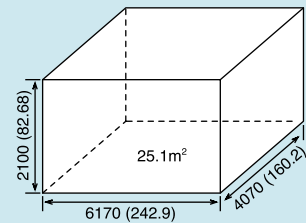

Outside dimensions  
W7395 x H2405 x D4200  
(W291.1 x H94.69 x D165.4)

\*Dimension shown above excludes protrusions.

## SPECIFICATIONS

Model	Walk-in type Temperature & Humidity Chamber			Walk-in type Temperature Chamber			
	EBE	EBL	EBR	EBF	EBU	EBUU	
System	Balanced Temperature & Humidity Control system (BTHC system) Vapor pressure divide control system (patent No.2928151)			Balanced Temperature Control system (BTC system)			
Refrigeration System	Single-stage refrigeration system (water-cooled condenser)	Single-stage refrigeration system (water-cooled/air-cooled condenser)		Single-stage refrigeration system (water-cooled condenser)	Single-stage refrigeration system (water-cooled/air-cooled condenser)		
Power Supply	200VAC 3 50/60Hz, 220VAC 3 60Hz, 380VAC 3 50Hz						
Performance*	Temp/Humid Range	-40 to +80 (-40 to +176°F)/ 10 to 95%rh	-30 to +80 (-22 to +176°F)/ 10 to 95%rh	-10 to +80 (14 to +176°F)/ 20 to 95%rh	-40 to +80 (-40 to +176°F)	-30 to +80 (-22 to +176°F)	-10 to +80 (14 to +176°F)
	Temp/Humid Fluctuation	±0.3 (0.54°F)/±2.5%rh			±0.3 (0.54°F)		
	Temp/Humid Uniformity	±0.75 (1.35°F)/±5.0%rh			±0.75 (1.35°F)		
	Temp Pull-down Rate	+20 to -40 (+68 to -40°F) within 180 min	+20 to -30 (+68 to -22°F) within 120 min	+20 to -10 (+68 to 14°F) within 100 min	+20 to -40 (+68 to -40°F) within 180 min	+20 to -30 (+68 to -22°F) within 120 min	+20 to -10 (+68 to 14°F) within 100 min
	Temp Heat-up Rate	+20 to +80 (+68 to 176°F)/within 60 min					
Chamber proper (Panel assembly)	Exterior Material	PVC coated steel					
	Interior Material	Stainless steel plate (SUS 304)					
	Floor Load Capacity	6kPa (equal load distribution)					
	Door	Single opening door: 850W × 1800Hmm (33.46W × 70.87H inch)					
	Thermal insulation	Hard urethane foam [t: 64mm (2.52 inch)]					
Air Conditioner	Heater, Evaporator, Air circulator, Air-supply register, Dry/wet bulb temperature sensor, Wick pan, others			Heater, Evaporator, Air circulator, Air-supply register, Dry bulb temperature sensor, others			
Machinery Compartment	Refrigerator, Water supply/drain pipes, Pressure regulator valve, Strainer, Electric parts compartment, Humidifier, others			Refrigerator, Water supply/drain pipe, Strainer, Electric parts compartment, others			
Standard Equipment	Recorder (100mm), Viewing window, Cable port (Inside diameter 50mm), Chamber lamp, Ventilation system						

\* At +5 to +32 ambient temperature, cooling water temperature +5 to +32, measured 30 minutes after chamber performance stabilized, under no specimen, no load. (The range of voltage fluctuation is within ±5% of the rated voltage. On condition that there are no significant fluctuation of cooling water pressure.)  
Temperature pull-down rate for air-cooled specification is performance at +25 ambient temperature.  
Standard atmospheric pressure is 1.013hPa where chamber is assembled.  
Indicated temperature & humidity range, fluctuation, and uniformity are in accordance with Standard for Performance of temperature and humidity chamber (JTM K03-2001) of Japan Testing Machinery Association.

## SAFETY DEVICES

Air circulator	Breaker Thermal relay
Refrigerator	Compressor thermal switch Thermal relay High-pressure switch Air circulator thermal relay for condenser ventilation (air-cooled type only)
Heater	Breaker Local overheat detection thermal switch for air circulator
Humidifier (Temperature & humidity type)	Breaker Boil dry thermal switch Water supply monitor circuit Scale accumulation detection thermal switch
Others	Leakage breaker for power supply Door switch for power compartment Control circuit protection fuse Circuit breaker for light load Specimen power supply control terminal Upper and lower temp. (& humid.) limit alarm (built inside temp. & humid. controller) Burn-out detection circuit (built inside temp. & humid. controller) Watchdog timer (built inside temp. & humid. controller) Temperature overheat protector Reverse prevention relay Water suspension relay (for water-cooled type) Safety switch for personnel (option) Safety detection circuit for dehumidifier (option) Safety detection circuit for velocity controller inverter (option) Emergency stop switch (option)



DANGER

Do not use specimens which are explosive or inflammable, or which contain such substances. To do so could be hazardous, as this may lead to fire or explosion.

Do not place corrosive materials in the chamber. If corrosive substances or humidifying water is used, the life of the unit may be significantly shortened.



CAUTION

Be sure to read the instruction manual before operation.

## OPTIONS

### Paperless recorder

Records temperature inside the chamber. Additional inputs may also be recorded.

[Temperature type]

Temperature range: - 50 ~ + 100  
- 100 ~ + 100  
- 50 ~ + 150  
- 100 ~ + 150

Number of inputs:

Temperature 1 (5 more but turned OFF\*)

Data saving cycle: 5 sec

External recording media:

CF memory card (32MB)

\* Settings may be modified.

[Temperature and humidity type]

Temperature range: - 50 ~ + 100  
- 100 ~ + 100  
- 50 ~ + 150  
- 100 ~ + 150

Humidity range: 0~100%rh

Number of inputs:

Temperature 1 / Humidity 1  
(4 more but turned OFF\*)

Data saving cycle: 5 sec

External recording media:

CF memory cord (32MB)

\* Settings may be modified.



Paperless recorder

### Recorders (digital)

No.3 - 50 to + 100 / 180mm  
6-dot system

No.4 - 50 to + 100 /  
0 to 100%rh 180mm  
6-dot system



### Operation panel cover

Cover for the operation panel section  
(made of plastic)

### Viewing window modification

A standard window (180W × 289Hmm) can be changed to a larger type (440W × 295Hmm). Tempered heat-resistant glass with defogging heater is used.



Large viewing window

### Viewing window (installed in chamber wall)

A small type (350W × 250Hmm) and  
a large type (600W × 400Hmm).

A defogging type is available for both  
types.

### Entrance curtain

Prevents disturbance of atmospheric  
temp. and humid. within the chamber  
when opening and closing the door.

### Fluorescent lamp

Two types of fluorescent lamps are  
available: a standard type for chamber  
temperatures of + 5 to + 40 and a  
low temperature type for 0 to - 30 .  
Both are waterproof.

### Floor reinforcement

Distributes the concentrated load that  
occurs when specimens are carried into the  
chamber on a trolley, preventing distortions  
and dents in the floor. Additional frames  
to support the floor panels also enhance  
distributed load resistance.

### Insertion ramp

This ramp is used to move heavy test  
samples into the chamber. The ramp is  
available in a removable type and a  
lever type.

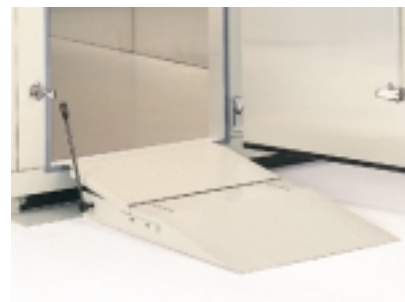

Insertion ramp

### Additional door

Two types are available: single-swing  
and double-swing doors. Both provide  
a viewing window (180W × 289Hmm).

### Door change

Single swing door (850W × 1800H  
mm) can be changed to double swing  
door (1400W × 1800Hmm).

## OPTIONS

### Operation port (with viewing window 350W x 250Hmm)

Two ports, each 150mm in diameter. Useful when handling specimens in the chamber from outside.

### Cable port

Used when introducing an external cable into the chamber. Four sizes of internal diameter: 25/50/100/150mm are available. A 50mm port is provided as a standard.



cable port

### Status indication lamp

The three status are displayed on one window.

### Operation status lamp

Provided above the door to indicate "OPERATION".

### Personnel indicator lamp

Indicates "PERSONNEL INSIDE" .

### Fault indicator lamp

Indicates "ALARM" in red.

### Flow switch (for water-cooled models only)

This safety switch for refrigeration unit activates when the cooling water level becomes too low or cut off and shuts down the equipment.

### Ceiling air duct (overall or partial covering)

Lowers and stabilize air circulation speed to protect specimen.

\*Effective height from floor to ceiling is lowered by 200mm.

### Exhaust air duct (for air-cooled type)

Exhausts hot air out of the refrigeration system. Installed on the upper part of the mechanical parts compartment.

### Shower defrost system

Application for EBE/EBF model with optional cascade refrigeration system. A sprinkler is activated with a cycle timer.

### Variable velocity device

Lowers air velocity in the chamber to minimize damage to specimens.

### Low humidity equipment (for temperature and humidity chambers only)

Expands the low-humidity range at low temperatures by using a dry-bulb dehumidifier.

### Additional refrigerator

You may equip another refrigerator to accommodate heat load.

### Thermocouple

Used to measure the temperature of any given measurement point in the chamber or specimen.

### Humidity sensor (for temperature and humidity chambers only)

Allows continuous operation for long periods without the need for wick changes. It enables measurement of low humidity ranges.

### Preparation room

Minimizes disturbance of atmospheric temperature and humidity when opening and closing the door. Also used as a measurement room for specimens.

### Cold-weather suit

For working long hours in chamber under low-temperature conditions. Two temperature types of - 30 and - 50 .

## OPTIONS

### Grounding terminal

Useful when certain types of testing equipment are to be used inside the chamber.

### Intercom

Allows contact of personnel inside and outside the chamber.



interior

exterior

### Operator safety switch

Protects personnel in the chamber by stopping operation and activating an alarm in case of emergency.



Operator safety switch

### In-chamber work timer

The alarm lamp and buzzer is activated to inform the operators when the preset working time limit is over.



In-chamber work timer

### Emergency stop switch (rotational reset type)

Immediately shuts down the equipment.



Emergency stop switch

### Revolving pilot lamp

In case of malfunction, the lamp connected to the safety circuit is activated, thus attracting the operator's attention even from a distance.

### Independent temperature overcooling alarm

In case of malfunction due to overcooling, operation is terminated and an alarm message is displayed, preventing freezing and damage to specimens inside the chamber.

### Gas alarm

Detects concentrations of various gases in the chamber and sounds a safety alarm when necessary to protect the personnel during a continuous operation.

### Rubber protective flooring

Prevents operators from slipping and prevents damage and dents to the floor.

### Interior plug socket

We provide two types of sockets according to use.



### Timer signals (8 points)

Eight points of timer signals (relay contacts) can be used to apply power, signals, etc., to the test sample.

### Communication function

- RS-485
- RS-232C
- E-BUS
- GP-IB

### Auxiliary humidifier (for temperature & humidity chambers only)

Effective for heat load generation and high humidity specification. Should use pure water.

### Water purifier (for temperature & humidity chambers only)

This is for auxiliary humidifier (optional) but can be connected to boiler humidifier and wet-bulb temperature sensor. It allows continuous operation for long periods and lengthens chamber's life.

Some photographs listed in this catalog contain Japanese display.

**ESPEC CORP.** <http://www.espec.co.jp/english>

**Head Office**

3-5-6, Tenjinbashi, Kita-ku, Osaka 530-8550, Japan

Tel: 81-6-6358-4741 Fax: 81-6-6358-5500

**Europe Office**

Tel: 49-6196-77-99980 Fax: 49-6196-77-99985

**ESPEC NORTH AMERICA, INC.**

Tel: 1-616-896-6100 Fax: 1-616-896-6150

**ESPEC EVALUATION & TEST SYSTEMS, INC.**

Tel: 1-408-433-2295 Fax: 1-408-433-2296

**ESPEC ENVIRONMENTAL EQUIPMENT (SHANGHAI) CO., LTD.**

**Head Office**

Tel: 86-21-58303322 Fax: 86-21-58661781

**BEIJING Rep. Office**

Tel: 86-10-64627025 Fax: 86-10-64627036

**GUANGZHOU Rep. Office**

Tel: 86-20-83317826 Fax: 86-20-83317825

**SHENZHEN Rep. Office**

Tel: 86-755-83674422 Fax: 86-755-83674228

**SUZHOU Rep. Office**

Tel: 86-512-68664007 Fax: 86-512-68601994

**ESPEC TEST TECHNOLOGY (SHANGHAI) CO., LTD.**

Tel: 86-21-68798008 Fax: 86-21-68798088

**ESPEC (MALAYSIA) SDN. BHD.**

Tel: 60-3-89451377 Fax: 60-3-89451287



JIS Q 9001:2000  
Registration Number  
JSAQ 004



JAB Certificate Number  
R001



RE 009



**ISO 9001/JIS Q 9001**

**Quality Management System Assessed and Registered**

ESPEC CORP. has been assessed by and registered in the Quality Management System based on the International Standard ISO 9001:2000 (JIS Q 9001:2000) through the Japanese Standards Association (JSA).

**ISO 14001 (JIS Q 14001)**

**Environmental Management System Assessed and Registered**

ESPEC GROUP

ESPEC CORP.

ESPEC ENGINEERING CORP.

ESPEC KANSAI CORP.

ESPEC ENVIRONMENTAL TEST

TECHNOLOGY CENTER CORP.

ESPEC BUSINESS CREATE CORP.

•Specifications are subject to change without notice due to design improvements.

•Windows® is a trademark or registered trademark of Microsoft Corporation in the U.S.A. and other countries. Other corporate names and trade names mentioned in this catalog are trademarks or registered trademarks.

•Printed on recycled paper.