

Variable speed drives
Altivar 31
High performance
instinctively!

Catalogue
October

03



For 3-phase asynchronous motors from 0.18 to 15 kW

Variable speed drives for asynchronous motors

Altivar 31

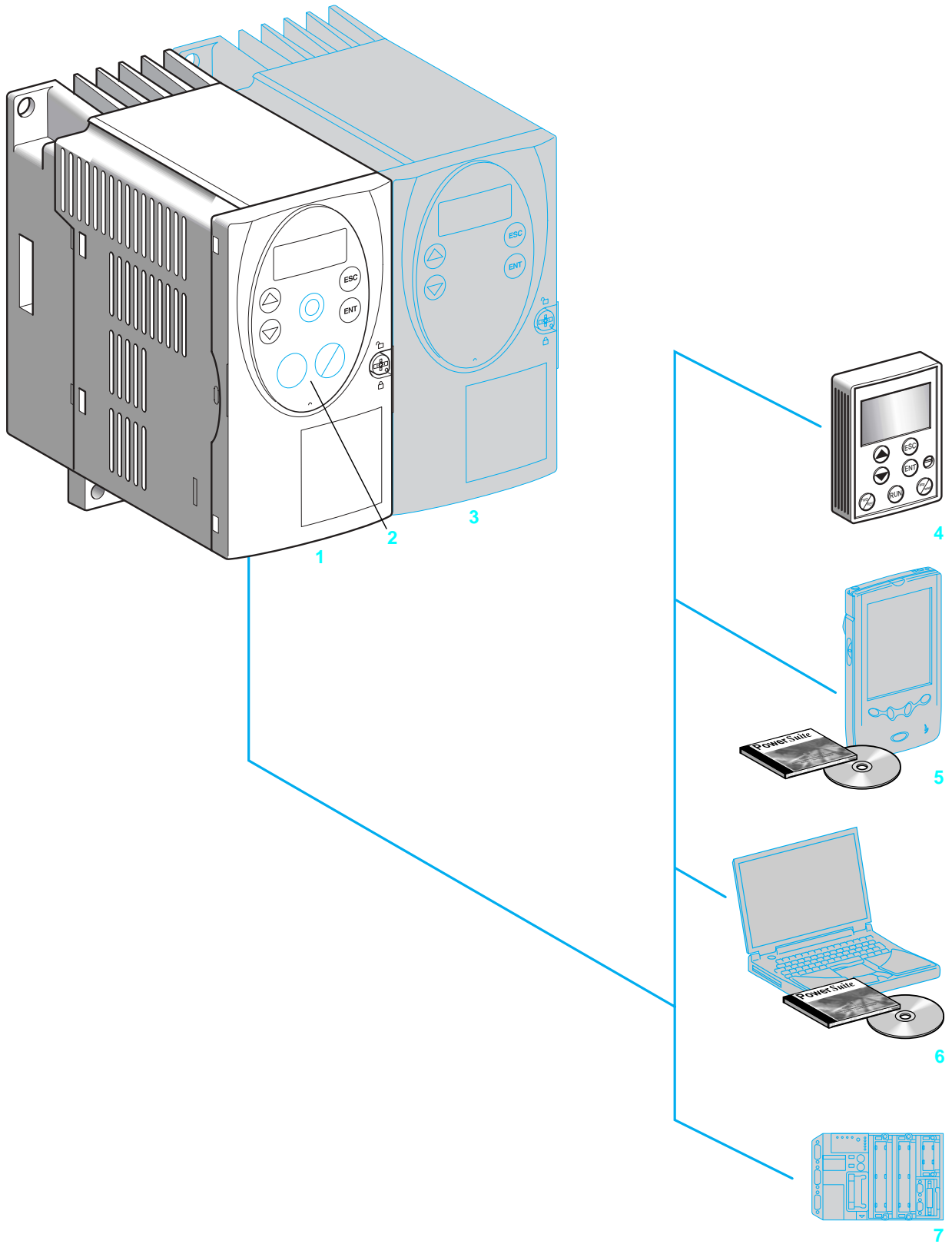

Variable speed drives for asynchronous motors

Altivar 31

Applications

The Altivar 31 drive is a frequency inverter for 3-phase squirrel cage asynchronous motors. The Altivar 31 is robust, compact, easy to use and conforms to EN 50178, IEC/EN 61800-2, IEC/EN 61800-3 standards, UL/CSA certification and to C€ marking.

It incorporates functions that are suitable for the most common applications, including:

- Materials handling (small conveyors, hoists, etc),
- Packing and packaging machines,
- Specialist machines (mixers, kneaders, textile machines, etc.),
- Pumps, compressors, fans.

Altivar 31 drives communicate on Modbus and CANopen industrial buses. These two protocols are integrated as standard into the drive.

Altivar 31 drives are supplied with a heatsink for normal environments and ventilated enclosures. Multiple units can be mounted side by side **3** to save space.

Drives are available for motor ratings between 0.18 kW and 15 kW, with four types of power supply:

- 200 V to 240 V single phase, 0.18 kW to 2.2 kW
- 200 V to 240 V 3-phase, 0.18 kW to 15 kW
- 380 V to 500 V 3-phase, 0.37 kW to 15 kW
- 525 V to 600 V 3-phase, 0.75 kW to 15 kW

Altivar 31 drives are available with a choice of two different human-machine interfaces:

- **1** **ATV 31H●●●●** with displays and menu navigation keys
- **2** **ATV 31H●●●●A** with displays, menu navigation keys and local control (Run/Stop and speed reference set by a potentiometer).

Electromagnetic compatibility EMC

The incorporation of level A EMC filters (conducted and radiated) in **ATV 31H●●M2** and **ATV 31H●●N4** drives simplifies the installation of machines and provides an economical means of meeting C€ marking requirements.

ATV 31H●●M3X and **ATV 31H●●S6X** drives are available without EMC filter. Filters are available as an option for customer assembly, if conformity to EMC standards is required.

Functions

The Altivar 31 drive has six logic inputs, three analog inputs, one logic/analog output and two relay outputs.

The main functions integrated in the drive are as follows:

- Motor and drive protection
 - Linear, S, U and customised acceleration and deceleration ramps
 - +/- speed
 - 16 preset speeds
 - PI references and regulator
 - 2-wire/3-wire control
 - Brake sequence
 - Automatic catching a spinning load with speed detection and automatic restart
 - Fault configuration and stop type configuration
 - Saving the configuration in the drive
- Several functions can be assigned to one logic input.

Options and accessories

The following options and accessories can be used with the Altivar 31 drive:

- Braking resistors
- Line chokes
- EMC radio interference input filters and output filters
- Plates for mounting on  rail
- UL Type 1 conformity kit
- Adaptor plate for replacing an Altivar 28 drive

Various dialogue and communication options **4**, **5**, **6**, **7** can be used with the drive, see pages 7 and 8.

Variable speed drives for asynchronous motors

Altivar 31
Enclosed drive

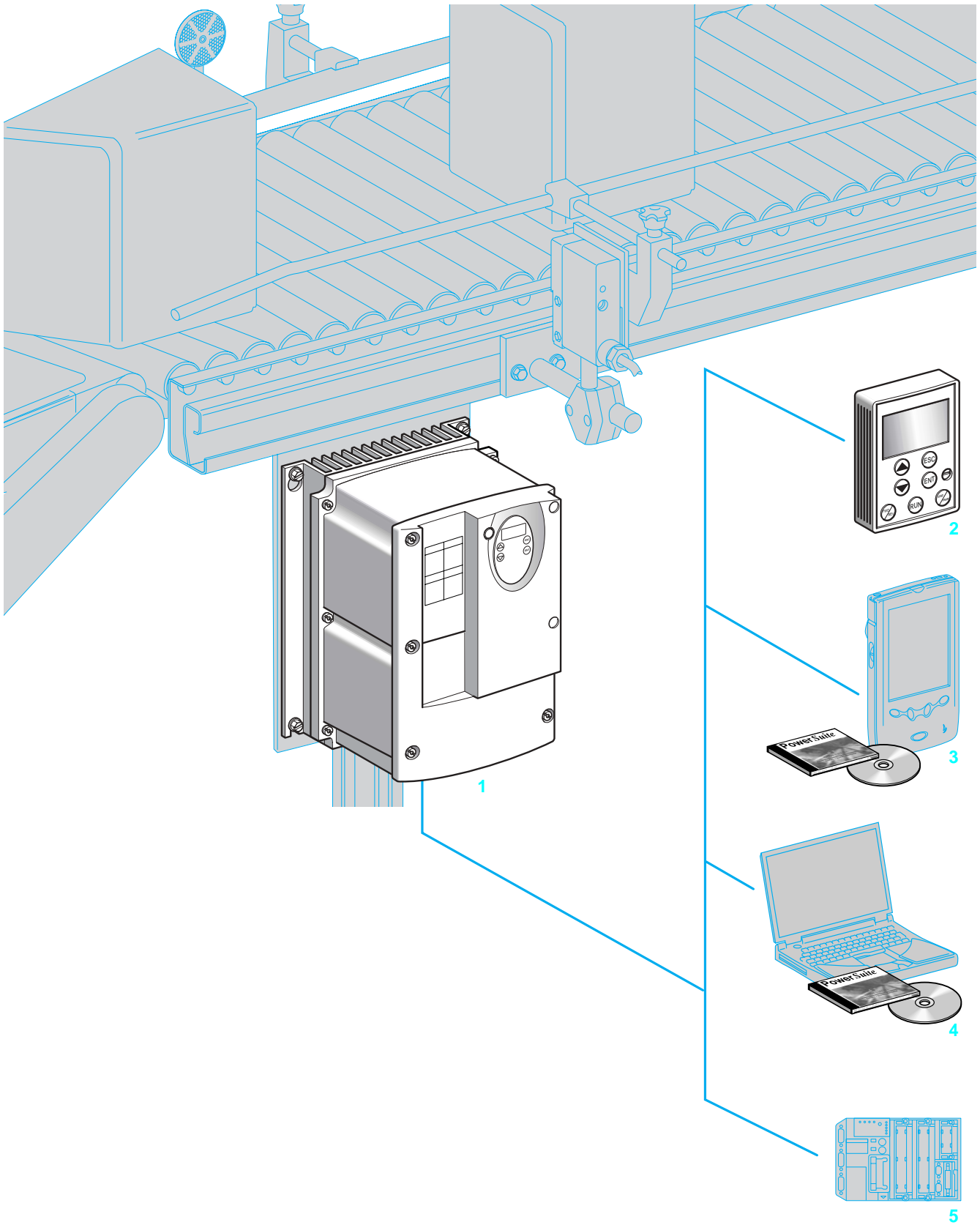

Variable speed drives for asynchronous motors

Altivar 31 Enclosed drive

Applications

The enclosed Altivar 31 drive is suitable for applications requiring:

- IP 55 degree of protection in a hostile environment
- a drive that is ready for use in a motor starter

Once it has been customised, the enclosure can be installed next to the motor. Enclosed drives are available in power ratings from 0.18 kW to 4 kW.

There are two types of power supply:

- 200 V to 240 V single phase, 0.18 kW and 2.2 kW
- 380 V to 500 V 3-phase, 0.37 kW and 4 kW

Customisable enclosed drive

This range allows full customisation of the human-machine interface of an enclosure.

The IP 55 enclosure includes:

- a drive with external heatsink
- removable covers for installation of the following components:
 - 7 Vario switch disconnecter or GV2 circuit-breaker
 - 8 3 buttons and/or LEDs with plastic flange Ø 22, and 1 speed reference potentiometer
 - 9 button for the RJ45 connector with IP 55 cable
 - 10 cable glands for cable routing

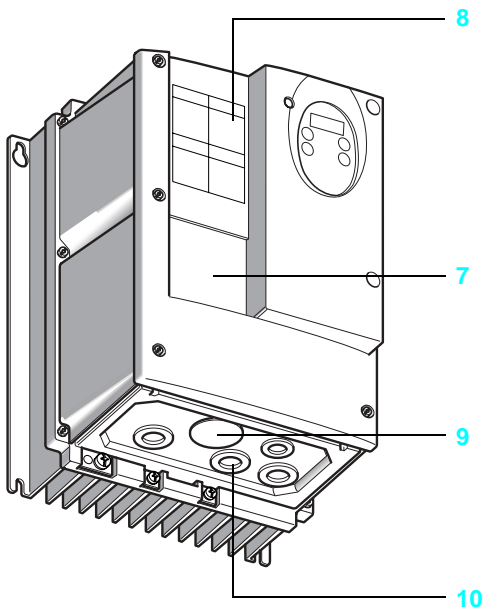

The combinations (drive, circuit-breaker, contactor) required for the motor starter function can be found on pages 40 and 41.

Example references:

- 3-pole Vario switch disconnecter (V●● + KC● 1●Z)
- Selector switch with 3 fixed positions XB5 D33
- LED XB5 AV●●
- 2.2 kOhm potentiometer

These references can be found in our specialist catalogues.

All components must be ordered separately and wired by the customer.

Electromagnetic compatibility EMC

The incorporation of level A EMC filters (conducted and radiated) in **ATV 31C●●M2** and **ATV 31C●●N4** drives simplifies the installation of machines and provides an economical means of meeting C€ marking requirements.

Options and accessories

The following options and accessories can be used with the enclosed Altivar 31 drive:

- Braking resistors
- Line chokes
- RJ45 connector with IP 55 cable

Various dialogue and communication options [2](#), [3](#), [4](#), [5](#) can be used with the drive, see pages 7 and 8.

Variable speed drives for asynchronous motors

Altivar 31
Drive kit

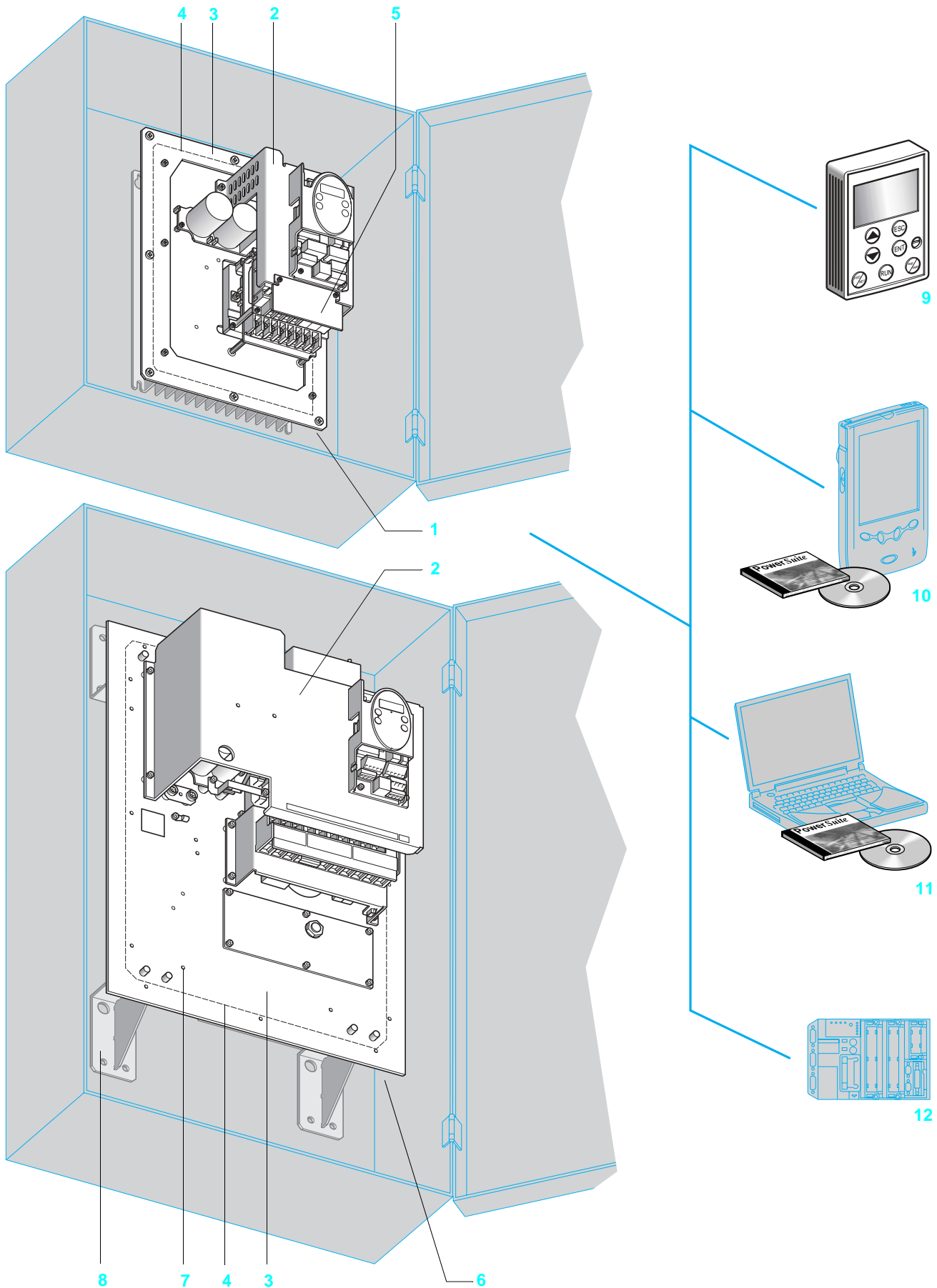

Variable speed drives for asynchronous motors

Altivar 31 Drive kit

Applications

The drive kit is a new addition to the Altivar 31 drives range.

The drive kit comprises:

- Altivar 31 drive elements (heatsink, power and control subassemblies)
- EMC filter
- Mechanical fittings
- Seals required for use in difficult environments (IP 55)

The kit is mounted on a metal fixing support with no flange or protective cover.

The Altivar 31 drive kit can be built into a floor-standing or wall-mounted enclosure or a machine frame.

The drive kit is available for power ratings from 0.18 kW to 15 kW.

There are two types of power supply:

- 200 V to 240 V single phase, 0.18 kW to 2.2 kW
- 380 V to 500 V 3-phase, 0.37 kW to 15 kW

Electromagnetic compatibility EMC

The incorporation of level A EMC filters (conducted and radiated) in **ATV 31K●●M2** and **ATV 31K●●N4** drives simplifies the installation of machines and provides an economical means of meeting CE marking requirements. The drives have been sized to conform to the following standards: IEC/EN61800-3, domestic and industrial environments.

Description

- Drive kit for power ratings ≤ 4 kW **1**

The Altivar 31 drive components (heatsink, power and control subassemblies) are fixed by mechanical adaptors **2** and protective fittings.

The unit is supported by a metal plate **3** fixed to the heatsink.

The plate is sealed on all sides.

Once the support has been cut out, the drive kit is fixed to the base of the floor-standing or wall-mounted enclosure by means of this plate.

The power terminals **5** are protected (IP 20).

- Drive kit for power ratings ≥ 5.5 kW **6**

The Altivar 31 drive components (heatsink, power and control subassemblies) are fixed by mechanical adaptors **2** and protective fittings.

The metal support plate **3** for the components is fitted with brackets **8** for mounting in a floor-standing or wall-mounted enclosure.

The plate is sealed on all sides **4**.

Two fans are fitted behind the plate under the heatsink.

Additional fixing holes **7** are provided for component mounting (GV2 circuit-breaker, Vario switch disconnecter, additional plate, etc.).

Drive kits are supplied with:

- A drilling and cutting template to assist with installation
- A user's manual with installation instructions and safety precautions.

Options and accessories

The following options and accessories can be used with the Altivar 31 drive kit:

- Braking resistors
- Line chokes

Various dialogue and communication options **9**, **10**, **11**, **12** can be used with the drive, see pages 7 and 8.

Variable speed drives for asynchronous motors

Altivar 31 Dialogue options

The Altivar 31 drive communicates with the following options:

- Remote terminal
- PowerSuite software workshop
- Ethernet/Modbus bridge
- Communication gateways

The communication function provides access to the drive's configuration, adjustment, control and signalling functions.

Remote terminal

The Altivar 31 can be connected to a remote terminal.

The remote terminal can be mounted on the door of an enclosure with IP 65 protection on the front panel.

The terminal provides access to the same functions as the display and integral keys on the drive (see page 45).

It can be used:

- to control, adjust and configure the drive remotely
- for visible remote signalling
- to save and download configurations (4 configuration files can be saved)

Description

1 Display

- Four 7-segment displays visible at 5 m
- Displays numeric values and codes
- The display flashes when a value is stored.
- The display flashes to indicate a fault on the drive.

2 Use of keys:

- Navigation arrows and ENT, ESC for settings and configurations
- FWD/REV key: reverses the direction of rotation of the motor
- RUN key: motor run command
- STOP/RESET key: motor stop command or drive fault reset

565220

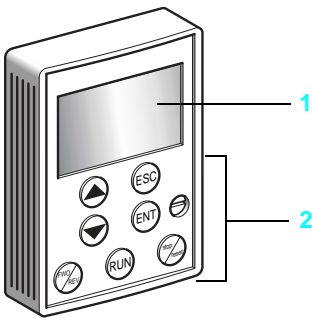

Variable speed drives for asynchronous motors

Altivar 31

Communication options

563019



PowerSuite software workshop

PowerSuite advanced dialogue solutions offer the following advantages:

- Display messages in plain text and multiple languages
- Prepare work in design office without connecting the Altivar to the PC
- Save configurations and settings to floppy disk or hard disk and download them to the drive
- Print out settings
- Read and import Altivar 28 files into the Altivar 31.

See pages 28 and 29.

563016



174 CEV 300 10

Ethernet/Modbus bridge

The Altivar 31 can be connected to an Ethernet network via an Ethernet/Modbus bridge.

Ethernet communication is primarily intended for the following applications:

- Coordination between PLCs
- Local or centralised supervision
- Communication with production management software
- Communication with remote I/O
- Communication with industrial control products

See pages 26 and 27.

563017



LUF P1

Communication gateways

The Altivar 31 can connect to other communication buses by means of the following gateways:

- Fipio/Modbus,
- DeviceNet/Modbus
- Profibus DP/Modbus

See pages 26 and 27.

563018

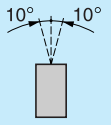

LA9 P307

Environment			
Conformity to standards		Altivar 31 drives have been developed to conform to the strictest international standards and the recommendations relating to electrical industrial control devices (IEC, EN), in particular: low-voltage EN 50178, EMC immunity and EMC conducted and radiated emissions.	
EMC immunity		<ul style="list-style-type: none"> ■ IEC/EN 61000-4-2 level 3 ■ IEC/EN 61000-4-3 level 3 ■ IEC/EN 61000-4-4 level 4 ■ IEC/EN 61000-4-5 level 3 (power access) ■ IEC/EN 61800-3, environments 1 and 2 	
EMC conducted and radiated emissions for drives			
All		■ IEC/EN 61800-3, environments: 2 (industrial supply) and 1 (public supply) restricted distribution	
ATV 31H018M2...HU15M2, ATV 31C018M2...CU15M2, ATV 31H037N4...HU40N4, ATV 31C037N4...CU40N4		<ul style="list-style-type: none"> ■ EN 55011 class A group 1, EN 61800-3 category C2 With additional EMC filter: <ul style="list-style-type: none"> ■ EN 55022 class B group 1, EN 61800-3 category C1 	
ATV 31HU22M2, ATV 31CU22M2, ATV 31HU55N4...HD15N4.		<ul style="list-style-type: none"> ■ EN 55011 class A group 2, EN 61800-3 category C3 With additional EMC filter (1): <ul style="list-style-type: none"> ■ EN 55022 class A group 1, EN 61800-3 category C2 ■ EN 55022 class B group 1, EN 61800-3 category C1 	
ATV 31H018M3X...HD15M3X, ATV 31H075S6X...HD15S6X		With additional EMC filter (1): <ul style="list-style-type: none"> ■ EN 55011 class A group 1, EN 61800-3 category C2 ■ EN 55022 class B group 1, EN 61800-3 category C1 	
CE marking		The drives bear CE marking in accordance with the European low voltage (73/23/EEC and 93/68/EEC) and EMC (89/336/EEC) directives	
Product certification		UL, CSA, NOM 117 and C-Tick	
Degree of protection	ATV 31H●●●M2, ATV 31H●●●N4, ATV 31H●●●M3X, ATV 31H●●●S6X ATV 31C●●●M2, ATV 31C●●●N4	<ul style="list-style-type: none"> ■ IP 31 and IP 41 on upper part and IP 21 on connection terminals ■ IP 20 without cover plate on upper part of cover ■ IP 55 	
Degree of pollution		2	
Climatic treatment		TC	
Vibration resistance	Drive without  rail option	Conforming to IEC/EN 60068-2-6: 1.5 mm peak to peak from 3 to 13 Hz, 1 gn from 13 to 150 Hz	
Shock resistance		15 gn for 11 ms conforming to IEC/EN 60068-2-27	
Relative humidity		% 5...95 without condensation or dripping water, conforming to IEC 60068-2-3	
Ambient temperature around the unit	Storage	°C - 25...+ 70	
	Operation	ATV 31H●●●	°C - 10...+ 50 without derating, with protective cover on top of the drive - 10...+ 60 with derating, without protective cover on top of the drive (see derating curves, page 36)
		ATV 31C●●●, ATV 31K●●●	°C - 10...+ 40 without derating
Maximum operating altitude		m 1000 without derating (above this, derate the current by 1% per additional 100 m)	
Operating position Maximum permanent angle in relation to the normal vertical mounting position			
Drive characteristics			
Output frequency range		Hz 0...500	
Switching frequency		kHz 2...16 adjustable during operation	
Speed range		1...50	
Transient overtorque		170-200% of nominal motor torque (typical value)	
Braking torque	With braking resistor	100% of nominal motor torque continuously and up to 150% for 60 s	
	Without braking resistor	Value of nominal motor torque (typical value) according to ratings: 30% for > ATV 31●U15●● 50% for ≤ ATV 31●U15●● 100% for ≤ ATV 31●075●● 150% for ≤ ATV 31●018M2	
Maximum transient current		150% of the nominal drive current for 60 seconds (typical value)	
Voltage/frequency ratio		Sensorless flux vector control with PWM (<i>pulse width modulation</i>) type motor control signal. Factory-set for most constant torque applications. Possible options: specific ratios for pumps and fans, energy saving or constant torque U/f for special motors.	
Frequency loop gain		Factory-set with the speed loop stability and gain Possible options for machines with high resistive torque or high inertia, or for machines with fast cycles.	
Slip compensation		Automatic whatever the load. Can be suppressed or adjusted.	

(1) See table on page 23 to check authorised cable lengths

Electrical characteristics			
Power supply	Voltage	V	200 - 15% to 240 + 10% single phase for ATV 31●●●●M2● 200 - 15% to 240 + 10% 3-phase for ATV 31●●●●M3X 380 - 15% to 500 + 10% 3-phase for ATV 31●●●●N4● 525 - 15% to 600 + 10% 3-phase for ATV 31●●●●S6X
	Frequency	Hz	50 - 5% to 60 + 5%
Prospective short-circuit current ICC	For drives		
	ATV 31●●●●M2	A	≤ 1000 (ICC at connection point) for single phase power supply
	ATV 31H018M3X...HU40M3X, ATV 31●037N4...●U40N4, ATV 31H075S6X...HU40S6X	A	≤ 5000 (ICC at connection point) for 3-phase power supply
	ATV 31HU55M3X...HD15M3X, ATV 31HU55N4...HD15N4, ATV 31KU55N4...KD15N4, ATV 31HU55S6X...HD15S6X	A	≤ 22000 (ICC at connection point) for 3-phase power supply
Output voltage			Maximum 3-phase voltage equal to line supply voltage.
Maximum connection capacity and tightening torque of the power supply terminals, motor, braking module and DC bus	For drives		
	ATV 31H018M2...H075M2, ATV 31H018M3X...HU15M3X		2.5 mm ² (AWG 14) 0.8 Nm
	ATV 31HU11M2...HU22M2, ATV 31HU22M3X...HU40M3X, ATV 31H037N4...HU40N4, ATV 31H075S6X...HU40S6X		6 mm ² (AWG 10) 1.2 Nm
	ATV 31HU55M3X, HU75M3X, ATV 31HU55N4, HU75N4, ATV 31HU55S6X, HU75S6X		16 mm ² (AWG 6) 2.2 Nm
	ATV 31HD11M3X, HD15M3X, ATV 31HD11N4, HD15N4, ATV 31HD11S6X, HD15S6X		25 mm ² (AWG 3) 4 Nm
Electrical isolation			Electrical isolation between power and control (inputs, outputs, power supplies)
Internal supplies available			Short-circuit and overload protection: - One +10 V (0/+ 8%) supply for the reference potentiometer (2.2 to 10 kΩ), maximum current 10 mA - One + 24 V supply (min. 19 V, max. 30 V) for logic inputs, maximum current 100 mA
Configurable analog inputs			3 configurable analog inputs AI1, AI2, AI3. ■ AI1: analog voltage input 0 to +10V, impedance 30 kΩ (maximum safe voltage 30 V) ■ AI2: analog bipolar voltage input ±10 V, impedance 30 kΩ (maximum safe voltage 30 V) ■ AI3: analog current input X-Y mA by programming X and Y from 0 to 20 mA, with impedance 250 Ω AIP: potentiometer reference for ATV31●●●●A only Max. sampling time: 8 ms 10-bit resolution Precision ± 4.3% Linearity ± 0.2% of maximum value Use: - 100 m maximum with shielded cable - 25 m maximum with unshielded cable
Analog output configurable for voltage, current and logic output			1 analog output configurable for voltage, current. ■ AOC: analog current output 0 to 20 mA, maximum load impedance 800 Ω ■ AOV: analog voltage output 0 to +10V, minimum load impedance 470 Ω 8-bit resolution Precision ± 1% Linearity ± 0.2% Only analog output AOC is configurable as a logic output. ■ AOC: operation as logic output 24 V 20 mA max. Max. sampling time: 8 ms
Configurable relay outputs	R1A, R1B, R1C		1 relay logic output, one "N/C" contact and one "N/O" contact with common point. Minimum switching capacity: 10 mA for ∼ 5 V. Maximum switching capacity: ■ on resistive load (cos φ = 1 and L/R = 0 ms): 5 A for ∼ 250 V or ∼ 30 V ■ on inductive load (cos φ = 0.4 and L/R = 7 ms): 2 A for ∼ 250 V or ∼ 30 V Max. sampling time: 8 ms Switching: 100,000 operations
	R2A, R2B		1 relay logic output, one "N/C" contact, contact open on fault. Minimum switching capacity: 10 mA for ∼ 5 V. Maximum switching capacity: ■ on resistive load (cos φ = 1 and L/R = 0 ms): 5 A for ∼ 250 V or ∼ 30 V ■ on inductive load (cos φ = 0.4 and L/R = 7 ms): 2 A for ∼ 250 V or ∼ 30 V Max. sampling time: 8 ms Switching: 100,000 operations

Electrical characteristics (continued)

Logic inputs LI			6 programmable logic inputs Impedance 3.5 kΩ + 24 V internal or 24 V external power supply (min. 19 V, max. 30 V) Max. current: 100 mA Max. sampling time: 4 ms Multiple assignment makes it possible to configure several functions on one input (example: LI1 assigned to forward and preset speed 2, LI3 assigned to reverse and preset speed 3)
	Positive logic		State 0 if < 5 V or logic input not wired, state 1 if > 11 V
	Negative logic		State 0 if > 19 V or logic input not wired, state 1 if < 13 V
	CLI position		Connection to PLC output (see diagram page 36)
Maximum I/O connection capacity and tightening torque			2.5 mm ² (AWG 14) 0.6 Nm
Acceleration and deceleration ramps			Ramp profiles: <ul style="list-style-type: none"> ■ linear, can be adjusted separately from 0.1 to 999.9 s ■ S, U or customised Automatic adaptation of deceleration ramp time if braking capacities exceeded, possible inhibition of this adaptation (use of braking resistor).
Braking to a standstill			By d.c. injection: <ul style="list-style-type: none"> ■ by a signal on a programmable logic input ■ automatically as soon as the estimated output frequency drops to < 0.5 Hz, period adjustable from 0 to 30 s or continuous, current adjustable from 0 to 1.2 In
Main protection and safety features of the drive			<ul style="list-style-type: none"> ■ Thermal protection against overheating ■ Protection against short-circuits between motor phases ■ Protection against input phase breaks ■ Protection against motor phase breaks ■ Protection against overcurrent between output phases and earth ■ Line supply undervoltage and overvoltage safety circuits ■ Line supply phase loss safety function, for 3-phase supply
Motor protection (see page 48)			Thermal protection integrated in the drive by continuous calculation of the I ² t
Dielectric strength	Between earth and power terminals		--- 2040 V for ATV 31●●●●M2 and M3X, --- 2410 V for ATV 31●●●●N4, --- 2550 V for ATV 31●●●●S6X
	Between control and power terminals		~ 2880 V for ATV 31●●●●M2 and M3X, ~ 3400 V for ATV 31●●●●N4, ~ 3600 V for ATV 31●●●●S6X
Insulation resistance to earth			> 500 MΩ (electrical isolation) --- 500 V for 1 minute
Signalling			1 red LED on front: LED lit indicates the presence of drive voltage Display coded by four 7-segment display units displaying the CANopen bus status (RUN and ERR).
Frequency resolution	Display units	Hz	0.1
	Analog inputs	Hz	0.1 to 100 Hz (calculate (high speed – low speed) /1024)
Time constant for reference change		ms	5
Communication			Modbus and CANopen are integrated into the drive and available via an RJ45 connector
	Modbus		RS 485 multidrop serial link <ul style="list-style-type: none"> ■ Modbus in RTU mode ■ Services supported: decimal function codes 03, 06, 16, 23 and 43 ■ Broadcasting ■ Number of addresses: drive address can be configured via the integrated terminal from 1 to 247 ■ Maximum number of Altivar 31 drives connected: 31 (two 470 Ω master pulldown resistors) ■ Transmission speed: 4800, 9600 or 19200 bps Used for connecting: <ul style="list-style-type: none"> ■ the remote terminal (option) ■ the PowerSuite software workshop ■ a PLC ■ a microprocessor card ■ a PC
	CANopen		To connect the ATV31 drive on the CANopen bus, use the VW3 CANTAP2 adapter. <ul style="list-style-type: none"> ■ Services supported: <ul style="list-style-type: none"> □ Implicit exchange of Process Data Object - 2 PDOs depending on DSP 402 velocity mode - 2 configurable PDOs (data and transmission type) - PDOs can be exchanged between slaves. □ Explicit exchange of Service Data Object - 1 receive SDO and 1 transmit SDO □ Boot-up messages, emergency messages, node guarding and producer and consumer heartbeat, sync and NMT ■ Number of addresses: drive address can be configured via the integrated terminal from 1 to 127 ■ Maximum number of Altivar 31 drives connected: 127 ■ Transmission speed: 10, 20, 50, 125, 250, 500 kbps or 1 Mbps

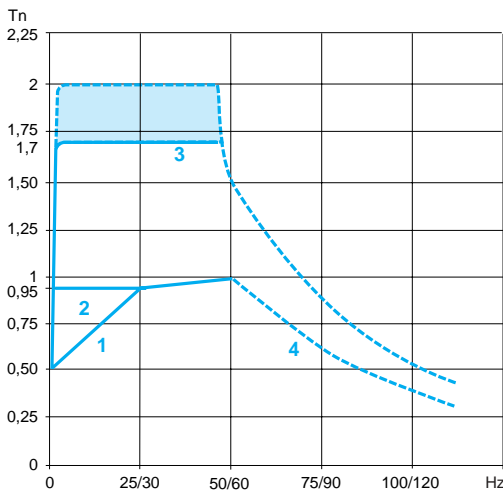

- 1 Self-cooled motor: continuous useful torque (1)
- 2 Force-cooled motor: continuous useful torque
- 3 Transient overtorque 1.7 to 2 T_n
- 4 Torque in overspeed at constant power (2)

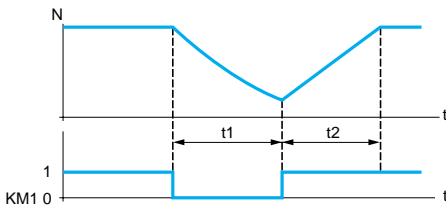

Torque characteristics (typical curves)

The curves below define the available continuous torque and transient overtorque for both force-cooled and self-cooled motors. The only difference is in the ability of the motor to provide a high continuous torque at less than half the nominal speed

Special uses

Use with a motor with a different rating to that of the drive

The device can supply any motor which has a power rating lower than that for which it is designed.

For motor ratings slightly higher than that of the drive, check that the current taken does not exceed the continuous output current of the drive.

Test on a low power motor or without a motor

In a testing or maintenance environment the drive can be checked without having to switch to a motor with the same rating as the drive (particularly useful in the case of high power drives). This use requires deactivation of motor phase loss detection.

Connecting motors in parallel

The rating of the drive must be greater than or equal to the sum of the currents of the motors to be connected to the drive.

In this case, external thermal protection must be provided for each motor using probes or LR2 thermal bimetal overload relays designed for a 1.2 I_n motor.

If the number of motors in parallel is greater than or equal to 3, it is advisable to install a 3-phase choke between the drive and the motors.

Switching the motor at the drive output

The drive can be switched when locked or unlocked. If the drive is switched on-the-fly (drive unlocked), the motor is controlled and accelerates until it reaches the reference speed smoothly following the acceleration ramp.

This use requires configuration of automatic catching a spinning load ("catch on the fly") and activation of the function which manages the presence of a downstream contactor.

Example: breaking of downstream contactor

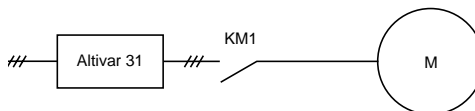

$t1$: deceleration without ramp (freewheel)

$t2$: acceleration with ramp

Typical applications: breaking safety circuit at drive outputs, "bypass" function, switching of motors connected in parallel.

(1) For power ratings ≤ 250 W, motor derating is less important (20% instead of 50% at very low frequencies).

(2) The nominal frequency of the motor and the maximum output frequency can be adjusted between 40 and 500 Hz.

Note: Check the mechanical overspeed characteristics of the selected motor with the manufacturer.

Variable speed drives for asynchronous motors

Altivar 31

Drives with heatsink (frequency range from 0.5 to 500 Hz)

Motor Power indicated on rating plate (1)	Line supply				Altivar 31			References (5)	Weight
	Line current (2)	Apparent power	Max. prospective line Isc (4)		Nominal current	Max. transient current for 60 s	Power dissipated at nominal load		
					at U1	at U2 (3)	4 kHz		

Single phase supply voltage: 200...240 V 50/60 Hz, with integrated EMC filters

kW	HP	A	A	kVA	kA	A	A	W		kg
0.18	0.25	3.0	2.5	0.6	1	1.5	2.3	24	ATV 31H018M2 (6)	1.500
0.37	0.5	5.3	4.4	1	1	3.3	5	41	ATV 31H037M2 (6)	1.500
0.55	0.75	6.8	5.8	1.4	1	3.7	5.6	46	ATV 31H055M2 (6)	1.500
0.75	1	8.9	7.5	1.8	1	4.8	7.2	60	ATV 31H075M2 (6)	1.500
1.1	1.5	12.1	10.2	2.4	1	6.9	10.4	74	ATV 31HU11M2 (6)	1.800
1.5	2	15.8	13.3	3.2	1	8	12	90	ATV 31HU15M2 (6)	1.800
2.2	3	21.9	18.4	4.4	1	11	16.5	123	ATV 31HU22M2 (6)	3.100

3-phase supply voltage: 200...240 V 50/60 Hz, without EMC filters (7)

kW	HP	A	A	kVA	kA	A	A	W		kg
0.18	0.25	2.1	1.9	0.7	5	1.5	2.3	23	ATV 31H018M3X (6)	1.300
0.37	0.5	3.8	3.3	1.3	5	3.3	5	38	ATV 31H037M3X (6)	1.300
0.55	0.75	4.9	4.2	1.7	5	3.7	5.6	43	ATV 31H055M3X (6)	1.300
0.75	1	6.4	5.6	2.2	5	4.8	7.2	55	ATV 31H075M3X (6)	1.300
1.1	1.5	8.5	7.4	3	5	6.9	10.4	71	ATV 31HU11M3X (6)	1.700
1.5	2	11.1	9.6	3.8	5	8	12	86	ATV 31HU15M3X (6)	1.700
2.2	3	14.9	13	5.2	5	11	16.5	114	ATV 31HU22M3X (6)	1.700
3	—	19.1	16.6	6.6	5	13.7	20.6	146	ATV 31HU30M3X (6)	2.900
4	5	24.2	21.1	8.4	5	17.5	26.3	180	ATV 31HU40M3X (6)	2.900
5.5	7.5	36.8	32	12.8	22	27.5	41.3	292	ATV 31HU55M3X (6)	6.400
7.5	10	46.8	40.9	16.2	22	33	49.5	388	ATV 31HU75M3X (6)	6.400
11	15	63.5	55.6	22	22	54	81	477	ATV 31HD11M3X (6)	10.500
15	20	82.1	71.9	28.5	22	66	99	628	ATV 31HD15M3X (6)	10.500

3-phase supply voltage: 380...500 V 50/60 Hz, with integrated EMC filters

kW	HP	A	A	kVA	kA	A	A	W		kg
0.37	0.5	2.2	1.7	1.5	5	1.5	2.3	32	ATV 31H037N4 (6)	1.800
0.55	0.75	2.8	2.2	1.8	5	1.9	2.9	37	ATV 31H055N4 (6)	1.800
0.75	1	3.6	2.7	2.4	5	2.3	3.5	41	ATV 31H075N4 (6)	1.800
1.1	1.5	4.9	3.7	3.2	5	3	4.5	48	ATV 31HU11N4 (6)	1.800
1.5	2	6.4	4.8	4.2	5	4.1	6.2	61	ATV 31HU15N4 (6)	1.800
2.2	3	8.9	6.7	5.9	5	5.5	8.3	79	ATV 31HU22N4 (6)	3.100
3	—	10.9	8.3	7.1	5	7.1	10.7	125	ATV 31HU30N4 (6)	3.100
4	5	13.9	10.6	9.2	5	9.5	14.3	150	ATV 31HU40N4 (6)	3.100
5.5	7.5	21.9	16.5	15	22	14.3	21.5	232	ATV 31HU55N4 (6)	6.500
7.5	10	27.7	21	18	22	17	25.5	269	ATV 31HU75N4 (6)	6.500
11	15	37.2	28.4	25	22	27.7	41.6	397	ATV 31HD11N4 (6)	11.000
15	20	48.2	36.8	32	22	33	49.5	492	ATV 31HD15N4 (6)	11.000

3-phase supply voltage: 525...600 V 50/60 Hz, without EMC filters (7)

kW	HP	A	A	kVA	kA	A	A	W		kg
0.75	1	8	2.4	2.5	5	1.7	2.6	36	ATV 31H075S6X	1.700
1.5	2	8	4.2	4.4	5	2.7	4.1	48	ATV 31HU15S6X	1.700
2.2	3	6.4	5.6	5.8	5	3.9	5.9	62	ATV 31HU22S6X	2.900
4	5	10.7	9.3	9.7	5	6.1	9.2	94	ATV 31HU40S6X	2.900
5.5	7.5	16.2	14.1	15	22	9	13.5	133	ATV 31HU55S6X	6.200
7.5	10	21.3	18.5	19	22	11	16.5	165	ATV 31HU75S6X	6.200
11	15	27.8	24.4	25	22	17	25.5	257	ATV 31HD11S6X	10.000
15	20	36.4	31.8	33	22	22	33	335	ATV 31HD15S6X	10.000

(1) These power ratings are for a maximum switching frequency of 4 kHz, in continuous operation. The switching frequency is adjustable from 2 to 16 kHz.

Above 4 kHz derate the nominal drive current. The nominal motor current should not exceed this value: see derating curve on page 38.

(2) Typical value for a 4-pole motor and a maximum switching frequency of 4 kHz, with no additional line choke, for the max. prospective line current.

(3) Nominal supply voltages, min. U1, max. U2 (200-240 V; 380-500 V; 525-600 V).

(4) If line Isc is greater than the values in the table, add line chokes (see page 21).

(5) To order a drive intended for wire guiding applications, add a T to the end of the reference.

(6) The drive can also be ordered complete with potentiometer. In this case add the letter A to the reference for the drive you require (e.g. ATV 31H018M2A).

(7) Optional EMC filter, see pages 22 and 23.



ATV 31H037M2



ATV 31HU40M3X



ATV 31HU75N4



ATV 31HD15N4A

Variable speed drives for asynchronous motors

Altivar 31 Enclosed drive



ATV 31C/H****

Customisable enclosed drives (frequency range from 0.5 to 500 Hz)

Motor Power indicated on rating plate (1)	Line supply		Apparent Max. power prospective line Isc (3)		Altivar 31			References (4)	Weight kg	
	Line current (2)		KVA	kA	Nominal current 4 kHz A	Max. transient current for 60 s A	Power dissipated at nominal load W			
	at U1 A	at U2 A								
Single phase supply voltage: 200...240 V (5) 50/60 Hz with integrated EMC filters										
0.18	0.25	3	2.5	0.6	1	1.5	2.3	24	ATV 31C018M2	6.300
0.37	0.5	5.3	4.4	1	1	3.3	5	41	ATV 31C037M2	6.300
0.55	0.75	6.8	5.8	1.4	1	3.7	5.6	46	ATV 31C055M2	6.300
0.75	1	8.9	7.5	1.8	1	4.8	7.2	60	ATV 31C075M2	6.300
1.1	1.5	12.1	10.2	2.4	1	6.9	10.4	74	ATV 31CU11M2	8.800
1.5	2	15.8	13.3	3.2	1	8	12	90	ATV 31CU15M2	8.800
2.2	3	21.9	18.4	4.4	1	11	16.5	123	ATV 31CU22M2	10.700
3-phase supply voltage: 380...500 V (5) 50/60 Hz with integrated EMC filters										
0.37	0.5	2.2	1.7	1.5	5	1.5	2.3	32	ATV 31C037N4	8.800
0.55	0.75	2.8	2.2	1.8	5	1.9	2.9	37	ATV 31C055N4	8.800
0.75	1	3.6	2.7	2.4	5	2.3	3.5	41	ATV 31C075N4	8.800
1.1	1.5	4.9	3.7	3.2	5	3	4.5	48	ATV 31CU11N4	8.800
1.5	2	6.4	4.8	4.2	5	4.1	6.2	61	ATV 31CU15N4	8.800
2.2	3	8.9	6.7	5.9	5	5.5	8.3	79	ATV 31CU22N4	10.700
3	–	10.9	8.3	7.1	5	7.1	10.7	125	ATV 31CU30N4	10.700
4	5	13.9	10.6	9.2	5	9.5	14.3	150	ATV 31CU40N4	10.700

Ready-assembled enclosed drives (frequency range from 0.5 to 500 Hz)

Please consult your Regional Sales Office.

- (1) These power ratings are for a maximum switching frequency of 4 kHz, in continuous operation. The switching frequency is adjustable from 2 to 16 kHz.
Above 4 kHz derate the nominal drive current. The nominal motor current should not exceed this value: see derating curve on page 38.
- (2) Typical value for a 4-pole motor and a maximum switching frequency of 4 kHz, with no additional line choke, for the max. prospective line current.
- (3) If line Isc is greater than the values in the table, add line chokes (see page 21).
- (4) To order a drive intended for wire guiding applications, add a T to the end of the reference.
- (5) Nominal supply voltages, min. U1, max. U2 (200-240 V; 380-500 V).

Variable speed drives for asynchronous motors

Altivar 31 Drive kit

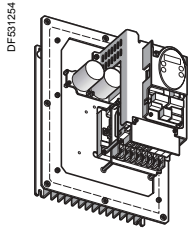

ATV 31K●●●●●

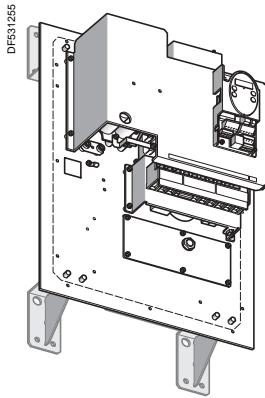

ATV 31K●●●●●

Drive kit (frequency range from 0.5 to 500 Hz)

Motor Power indicated on rating plate (1)		Line supply (2)				Altivar 31			References (4)	Weight
		Line current (2)		Apparent power KVA	Max. prospective line Isc (3) kA	Nominal current 4 kHz A	Max. transient current for 60 s A	Power dissipated at nominal load W		
kW	HP	at U1 A	at U2 A							
Single phase supply voltage: 200...240 V (5) 50/60 Hz with integrated filters										
0.18	0.25	3	2.5	0.6	1	1.5	2.3	24	ATV 31K018M2	6.300
0.37	0.5	5.3	4.4	1	1	3.3	5	41	ATV 31K037M2	6.300
0.55	0.75	6.8	5.8	1.4	1	3.7	5.6	46	ATV 31K055M2	6.300
0.75	1	8.9	7.5	1.8	1	4.8	7.2	60	ATV 31K075M2	6.300
1.1	1.5	12.1	10.2	2.4	1	6.9	10.4	74	ATV 31KU11M2	8.800
1.5	2	15.8	13.3	3.2	1	8	12	90	ATV 31KU15M2	8.800
2.2	3	21.9	18.4	4.4	1	11	16.5	123	ATV 31KU22M2	10.700
3-phase supply voltage: 380...500 V (5) 50/60 Hz with integrated filters										
0.37	0.5	2.2	1.7	1.5	5	1.5	2.3	32	ATV 31K037N4	8.800
0.55	0.75	2.8	2.2	1.8	5	1.9	2.9	37	ATV 31K055N4	8.800
0.75	1	3.6	2.7	2.4	5	2.3	3.5	41	ATV 31K075N4	8.800
1.1	1.5	4.9	3.7	3.2	5	3	4.5	48	ATV 31KU11N4	8.800
1.5	2	6.4	4.8	4.2	5	4.1	6.2	61	ATV 31KU15N4	8.800
2.2	3	8.9	6.7	5.9	5	5.5	8.3	79	ATV 31KU22N4	10.700
3	–	10.9	8.3	7.1	5	7.1	10.7	125	ATV 31KU30N4	10.700
4	5	13.9	10.6	9.2	5	9.5	14.3	150	ATV 31KU40N4	10.700
5.5	7.5	21.9	16.5	15	22	14.3	21.5	232	ATV 31KU55N4	16.500
7.5	10	27.7	21	18	22	17	25.5	269	ATV 31KU75N4	16.500
11	15	37.2	28.4	25	22	27.7	41.6	397	ATV 31KD11N4	23.000
15	20	48.2	36.8	32	22	33	49.5	492	ATV 31KD15N4	23.000

- (1) These power ratings are for a maximum switching frequency of 4 kHz, in continuous operation. The switching frequency is adjustable from 2 to 16 kHz.
Above 4 kHz derate the nominal drive current. The nominal motor current should not exceed this value: see derating curve on page 38.
- (2) Typical value for a 4-pole motor and a maximum switching frequency of 4 kHz, with no additional line choke, for the max. prospective line current.
- (3) If line Isc is greater than the values in the table, add line chokes (see page 21).
- (4) To order a drive intended for wire guiding applications, add a **T** to the end of the reference.
- (5) Nominal supply voltages, min. U1, max. U2 (200-240 V; 380-500 V).

Variable speed drives for asynchronous motors

Altivar 31 Accessories

Plate for mounting on rail

Description	For drives	Reference	Weight kg
Plate for mounting on  rail, width 35 mm	ATV 31H018M2, ATV 31H037M2, ATV 31H055M2, ATV 31H075M2, ATV 31H018M3X, ATV 31H037M3X, ATV H055M3X, ATV 31H075M3X	VW3 A11851	0.200
	ATV 31HU11M2, ATV 31HU15M2, ATV 31HU11M3X, ATV 31HU15M3X, ATV 31HU22M3X, ATV 31H037N4, ATV 31H055N4, ATV 31H075N4, ATV 31HU11N4, ATV 31HU15N4, ATV 31H075S6X, ATV 31HU15S6X	VW3 A31852	0.220

UL Type 1 conformity kit (1)

Description	For drives	Reference	Weight kg
Mechanical device fixing to the underside of the Altivar 31	ATV 31H018M2, ATV 31H037M2, ATV 31H055M2, ATV 31H075M2	VW3 A31812	0.400
	ATV 31H018M3X, ATV 31H037M3X, ATV H055M3X, ATV 31H075M3X	VW3 A31811	0.400
	ATV 31HU11M3X, ATV 31HU15M3X	VW3 A31813	0.400
	ATV 31HU11M2, ATV 31HU15M2, ATV 31HU22M3X, ATV 31H037N4, ATV 31H055N4, ATV 31H075N4, ATV 31HU11N4, ATV 31HU15N4, ATV 31H075S6X, ATV 31HU15S6X	VW3 A31814	0.500
	ATV 31HU22M2, ATV 31HU30M3X, ATV 31HU40M3X, ATV 31HU22N4, ATV 31HU30N4, ATV 31HU40N4, ATV 31HU22S6X, ATV 31HU40S6X	VW3 A31815	0.500
	ATV 31HU55M3X, ATV 31HU75M3X, ATV 31HU55N4, ATV 31HU75N4, ATV 31HU55S6X, ATV 31HU75S6X	VW3 A31816	0.900
	ATV 31HD11M3X, ATV 31HD15M3X, ATV 31HD11N4, ATV 31HD15N4, ATV 31HD11S6X, ATV 31HD15S6X	VW3 A31817	1.200

(1) This device allows cables to be connected directly to the drive using conduits or cable glands.

Altivar 28 substitution kit

Description	For drives	Reference	Weight kg
Mechanical adapters allowing an ATV 31 to be used in place of an ATV 28 of the same rating (using the same fixing holes)	ATV 31H018M2, ATV 31H037M2, ATV 31H055M2, ATV 31H075M2, ATV 31H018M3X, ATV 31H037M3X, ATV H055M3X, ATV 31H075M3X	VW3 A31821	–
	ATV 31HU11M2, ATV 31HU15M2, ATV 31HU11M3X, ATV 31HU15M3X, ATV 31HU22M3X, ATV 31H075S6X, ATV 31HU15S6X	VW3 A31822	–
	ATV 31HU55N4, ATV 31HU75N4, ATV 31HU55M3X, ATV 31HU75M3X, ATV 31HU55S6X, ATV 31HU75S6X	VW3 A31823	–

Remote terminal

Description	Reference	Weight kg
For ATV 31 drives of all ratings, assembly comprising: - terminal, cable fitted with 2 connectors - seal and screws for IP 65 mounting on an enclosure door	VW3 A31101	–

Documentation

Description	Reference	Weight kg
- Simplified ATV 31 user's manual and CD-ROM, comprising: - a User's manual for the drives - a User's manual for Modbus and CANopen	Supplied with the drive	–
International Technical Manual (ITM)	CD-ROM	DCI CD39811
		0.150



VW3 A31101

Presentation

The resistor enables the Altivar 31 drive to operate while braking to a standstill or in braked operation, by dissipating the braking energy.

Two types of resistor are available:

- enclosed model (IP 30 enclosure) designed to comply with EMC regulations and protected by a temperature-controlled switch or thermal relay
- non-protected model (IP00) for low power ratings only

They are designed for machine applications with high inertia, driving loads, machines with fast cycles.

Characteristics

References		VW3 A58702 to VW3 A58704	VW3 A58732 to VW3 A58735	VW3 A58736 and VW3 A58737	VW3 A66704
Ambient air temperature	°C	40			
Degree of protection of enclosure		IP 00	IP 30		IP 23
Resistor protection		None	By temperature-controlled switch (1)		By thermal relay (2)
Temperature-controlled switch	Trip temperature	°C	-	130 ± 5%	260 ± 14%
	Max. voltage - max. current		-	~ 110 V - 0.3 A	~ 220 V - 6 A
	Min. voltage - min. current		-	~ 24 V - 0.01 A	
	Maximum contact resistance	mΩ	-	150	50
Load factor of resistors		The value of the average power that can be dissipated by the resistor in the enclosure at 40°C is determined for a braking load factor corresponding to the majority of common applications: - braking for 2 seconds with a torque of 0.6 Tn every 40 seconds - braking for 0.8 second with a torque of 1.5 Tn every 40 seconds			
Load factor of drives		The internal circuits for drives used for braking on external resistors are sized for the following cycles. If they are exceeded, the drive will lock and display a fault. - 1.5 TN for 60 seconds per 140-second cycle - TN continuously			

(1) The contact must be connected in sequence (used for signalling or for controlling the line contactor).

(2) To be ordered separately, 8 A rating.

Load factor and determining the nominal power

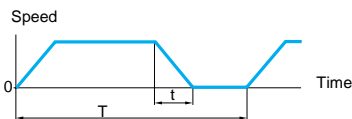

Load factor: $\frac{t}{T}$

t: braking time in s

T: cycle time in s

The value of the average power that can be dissipated by the resistor in the enclosure at 40°C is determined for a braking load factor corresponding to the majority of common applications. This load factor is defined above.

For a specific application (e.g. handling), the nominal resistor power has to be redefined by taking account of the new load factor.

Chart 1

Graph of the average power as a function of the braking torque for a load factor.

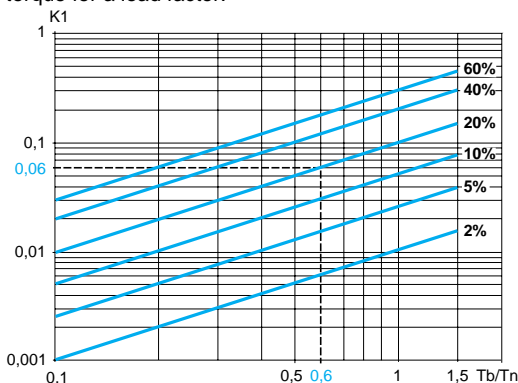

Example:

- Motor of power Pm = 4 kW
- Motor efficiency η = 0.85
- Braking torque Tb = 0.6 Tn
- Braking time t = 10 s
- Cycle time T = 50 s
- Load factor Lf = $\frac{t}{T}$ = 20%

Use chart 1 to determine the coefficient K1 corresponding to a braking torque of 0.6 Tn and a load factor of 20%. K1 = 0.06

Chart 2

Permissible resistor overload as a function of time (characteristic curve).

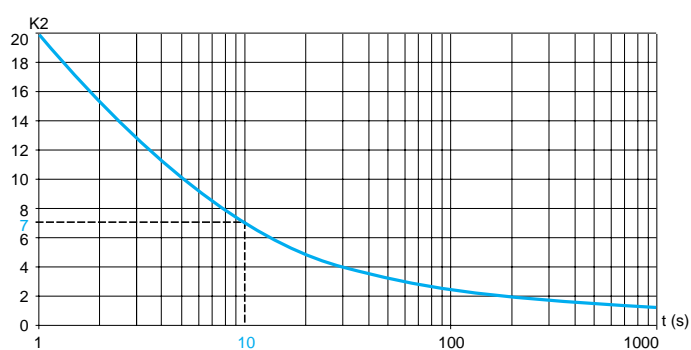

Use chart 2 to determine the coefficient K2 corresponding to a braking time of 10 seconds.

K2 = 7

The nominal resistor power (Pn) must be greater than:

$$P_n = P_m \times K_1 \times \eta \left(1 + \frac{1}{K_2 \times L_f} \right) = 4,10^3 \times 0,06 \times 0,85 \left(1 + \frac{1}{7 \times 0,2} \right) = 350W$$

Variable speed drives for asynchronous motors

Altivar 31

Options: braking resistors



VW3 A58702



VW3 A58733

For drives	Min. resistor value (1)	Ohmic value Ω	Average power available at		Reference	Weight kg
			40°C(2)	50°C		
	Ω	Ω	W	W		
Non-protected braking resistors						
ATV 31H/C/K018M2, ATV 31H/C/K037M2, ATV 31H/C/K055M2, ATV 31H/C/K075M2	40	100	32	28	VW3 A58702	0.600
ATV 31H/C/KU11M2, ATV 31H/C/KU15M2, ATV 31H018M3X, ATV 31H037M3X, ATV 31H055M3X, ATV 31H075M3X, ATV 31HU11M3X, ATV 31HU15M3X,	27 40 40 27					
ATV 31H/C/K037N4, ATV 31H/C/K055N4, ATV 31H/C/K075N4, ATV 31H/C/KU11N4, ATV 31H/C/KU15N4, ATV 31H/C/KU22N4	80 80 54 54					
ATV 31H075S6X ATV 31HU15S6X, ATV31HU22S6X	96 64					
ATV 31H/C/KU30N4, ATV 31H/C/KU40N4 ATV 31HU40S6X	55 36 44	100	40	35	VW3 A58703	0.850
ATV 31H/C/KU22M2, ATV 31HU22M3X, ATV 31HU30M3X	25 25 16	68	32	28	VW3 A58704	0.600
Protected braking resistors						
ATV 31H/C/K018M2, ATV 31H/C/K037M2, ATV 31H/C/K055M2, ATV 31H/C/K075M2, ATV 31H/C/KU11M2, ATV 31H/C/KU15M2, ATV 31H018M3X, ATV 31H037M3X, ATV 31H055M3X, ATV 31H075M3X, ATV 31HU11M3X, ATV 31HU15M3X,	40 40 27 40 40 27	100	32	28	VW3 A58732	2.000
ATV 31H/C/K037N4, ATV 31H/C/K055N4, ATV 31H/C/K075N4, AATV 31H/C/KU11N4, ATV 31H/C/KU15N4, ATV 31H/C/KU22N4	80 80 54 54					
ATV 31H/C/KU22M2, ATV 31HU22M3X, ATV 31HU30M3X	25 25 16	68	32	28	VW3 A58733	2.000
ATV 31H/C/KU30N4, ATV 31H/C/KU40N4 ATV 31HU22M3X, ATV 31HU30M3X	55 36 25 16					
ATV 31H/C/KU30N4, ATV 31H/C/KU40N4	55 36	100	40	35	VW3 A58734	2.000
ATV 31H/KU55N4, ATV 31H/KU75N4 ATV 31HU55S6X ATV 31HU75S6X	29 19 34 23	60	80	69	VW3 A58735	3.400
ATV 31HU40M3X ATV 31H/KD11N4, ATV 31H/KD15N4 ATV 31HD11S6X, ATV 31HD15S6X	16 20 24	28	200	173	VW3 A58736	5.100
ATV 31HU55M3X, ATV 31HU75M3X	8	14	400	346	VW3 A58737	6.100
ATV 31HD11M3X, ATV 31HD15M3X	5	10	1000	866	VW3 A66704 (3)	17.000

(1) Depends on the drive rating.

(2) Power that can be dissipated by the resistor at the maximum temperature of 115°C, corresponding to a maximum temperature rise of 75°C in a 40°C environment.

(3) The various ohmic values are obtained as a function of the connection, described in the resistor instructions.

Variable speed drives for asynchronous motors

Altivar 31

Options: line chokes

Presentation

These chokes provide improved protection against overvoltages on the line supply and reduce harmonic distortion of the current produced by the drive.

The recommended chokes are used to limit the line current.

They have been developed to conform to standard EN 50178 (VDE 0160 level 1 high energy overvoltages on the line supply).

The values of the chokes are defined for a voltage drop between 3% and 5% of the nominal line voltage. Values higher than this will cause loss of torque.

The use of line chokes is recommended in particular under the following circumstances:

- Line supply with significant disturbance from other equipment (interference, overvoltages)
- Line supply with voltage imbalance between phases > 1.8 % of nominal voltage
- Drive supplied with power by a line with very low impedance (in the vicinity of power transformers 10 times more powerful than the drive rating)

The prospective short-circuit current at the point of connection of the drive must not exceed the maximum value indicated in the tables of references. The use of line chokes allows connection on the following networks:

- Max. Isc 22 kA for 200/240 V
- Max. Isc 65 kA for 380/500 V and 525/600 V

- Installation of a large number of frequency converters on the same line
- Reduction of overload in cos ϕ correction capacitors, if the installation has a power factor correction unit

Type of line choke	VZ1 L00 4M010	VZ1 L00 7UM50	VZ1 L01 8UM20	VW3 A6 6501	VW3 A6 6502	VW3 A6 6503	VW3 A6 6504	VW3 A6 6505	VW3 A6 6506	
Characteristics										
Conformity to standards	EN 50178 (VDE 0160 level 1 high energy overvoltages on the line supply)									
Voltage drop	Between 3 and 5% of the nominal line voltage. Values higher than this will cause loss of torque.									
Degree of protection	Choke	IP 00								
	Terminals	IP 20						IP 10		IP 00
Value of choke	mH	10	5	2	10	4	2	1	0.5	0.3
Nominal current	A	4	7	18	4	10	16	30	60	100
Loss	W	17	20	30	45	65	75	90	80	–

Variable speed drives for asynchronous motors

Altivar 31

Options: line chokes

803887



VW3 A6650

Altivar 31 Single phase or 3-phase	Line current without choke		Line current with choke		Choke Reference	Weight kg
	at U min.	at U max.	at U min.	at U max.		
	A	A	A	A		
Single phase supply voltage: 200...240 V (1) 50/60 Hz						
ATV 31H/C/K018M2	3.0	2.5	2.1	1.8	VZ1 L004M010	0.630
ATV 31H/C/K037M2	5.3	4.4	3.9	3.3		
ATV 31H/C/K055M2	6.8	5.8	5.2	4.3	VZ1 L007UM50	0.880
ATV 31H/C/K075M2	8.9	7.5	7.0	5.9		
ATV 31H/C/KU11M2	12.1	10.2	10.2	8.6	VZ1 L018UM20	1.990
ATV 31H/C/KU15M2	15.8	13.3	13.4	11.4		
ATV 31H/C/KU22M2	21.9	18.4	19.2	16.1		
3-phase supply voltage: 200...240 V (1) 50/60 Hz						
ATV 31H018M3X	2.1	1.9	1	0.9	VW3 A66501	1.500
ATV 31H037M3X	3.8	3.3	1.9	1.6		
ATV 31H055M3X	4.9	4.2	2.5	2.2		
ATV 31H075M3X	6.4	5.6	3.3	2.9		
ATV 31HU11M3X	8.5	7.4	4.8	4.2	VW3 A66502	3.000
ATV 31HU15M3X	11.1	9.6	6.4	5.6		
ATV 31HU22M3X	14.9	13	9.2	8	VW3 A66503	3.500
ATV 31HU30M3X	19.1	16.6	12.3	10.7		
ATV 31HU40M3X	24.2	21.1	16.1	14	VW3 A66504	6.000
ATV 31HU55M3X	36.8	32	21.7	19		
ATV 31HU75M3X	46.8	40.9	29	25.2		
ATV 31HD11M3X	63.5	55.6	41.6	36.5	VW3 A66505	11.000
ATV 31HD15M3X	82.1	71.9	55.7	48.6		
3-phase supply voltage: 380...500 V (1) 50/60 Hz						
ATV 31H/C/K037N4	2.2	1.7	1.1	0.9	VW3 A66501	1.500
ATV 31H/C/K055N4	2.8	2.2	1.4	1.2		
ATV 31H/C/K075N4	3.6	2.7	1.8	1.5		
ATV 31H/C/KU11N4	4.9	3.7	2.6	2		
ATV 31H/C/KU15N4	6.4	4.8	3.4	2.6		
ATV 31H/C/KU22N4	8.9	6.7	5	4.1	VW3 A66502	3.000
ATV 31H/C/KU30N4	10.9	8.3	6.5	5.2		
ATV 31H/C/KU40N4	13.9	10.6	8.5	6.6		
ATV 31H/KU55N4	21.9	16.5	11.7	9.3	VW3 A66503	3.500
ATV 31H/KU75N4	27.7	21	15.4	12.1		
ATV 31H/KD11N4	37.2	28.4	22.5	18.1	VW3 A66504	6.000
ATV 31H/KD15N4	48.2	36.8	29.6	23.3		
3-phase supply voltage: 525...600 V (1) 50/60 Hz						
ATV 31H075S6X	2.5	2.4	1.4	1.4	VW3 A66501	1.500
ATV 31HU15S6X	4.4	4.2	2.4	2.3		
ATV 31HU22S6X	5.8	5.6	3.8	3.6		
ATV 31HU40S6X	9.7	9.3	6	5.8	VW3 A66502	3.000
ATV 31HU55S6X	14.7	14.1	7.8	7.5		
ATV 31HU75S6X	19.3	18.5	11	10.7	VW3 A66503	3.500
ATV 31HD11S6X	25.4	24.4	15	14.4		
ATV 31HD15S6X	33.2	31.8	21.1	20.6	VW3 A66504	6.000

(1) Nominal supply voltage: U min....U max.

Variable speed drives for asynchronous motors

Altivar 31

Options: additional EMC input filters

Presentation

Function

The Altivar 31 has built-in radio interference input filters to meet EMC "product" standards for variable speed drives IEC/EN 61800-3 and to comply with the European EMC (electromagnetic compatibility) directive.

The additional filters enable the drives to meet more stringent requirements: these filters are designed to reduce conducted emissions on the line supply below the limits of standards EN 55011 class A (1) or EN 55022 class B.

These additional filters are installed underneath ATV 31H drives. They can be installed at the side of the product in the case of ATV 31C and K drives. They act as supports for the drives and are fixed to them via tapped holes.

Use according to the type of network

Use of these additional filters is only possible on TN (neutral connection) and TT (neutral to earth) type networks.

The standard IEC 61800-3, annex D2.1, indicates that on IT (impedance earthed or isolated neutral) networks the filters can randomise the operation of insulation monitors.

The efficiency of additional filters on this type of network also depends on the nature of the impedance between neutral and earth and is therefore unpredictable.

If a machine is to be installed on an IT network, one solution is to insert an isolation transformer and to connect locally to the machine on a TN or TT network.

Characteristics

Conformity to standards			EN 133200
Degree of protection			IP 21 and IP 41 on upper part
Maximum relative humidity			93% without condensation or dripping water conforming to IEC 68-2-3
Ambient air temperature around the device	Operation	°C	- 10...+ 60
	Storage	°C	- 25...+ 70
Maximum operating altitude	Without derating	m	1000 (above this, derate the current by 1% per additional 100 m)
Vibration resistance	Conforming to IEC 60068-2-6		1.5 mm peak to peak from 3 to 13 Hz 1 gn peak from 13 to 150 Hz
Shock resistance	Conforming to IEC 60068-2-27		15 gn for 11 ms
Max. nominal voltage	50/60 Hz single phase	V	240 + 10%
	50/60 Hz 3-phase	V	240 + 10% 500 + 10% 600 + 10%

Variable speed drives for asynchronous motors

Altivar 31

Options: additional EMC input filters

For drives Reference	Filter		In (2)	II (3)	Loss (4)	Reference	Weight
	Maximum length of shielded cable	EN 55011 class A (1)					
	m	m	A	mA	W		kg
Single phase supply voltage: 200...240 V 50/60 Hz							
ATV 31H/C/K018M2	50	20	9	100	–	VW3 A31401	–
ATV 31H/C/K037M2							
ATV 31H/C/K055M2							
ATV 31H/C/K075M2							
ATV 31H/C/KU11M2	50	20	16	150	–	VW3 A31403	–
ATV 31H/C/KU15M2							
ATV 31H/C/KU22M2	50	20	22	80	–	VW3 A31405	–
3-phase supply voltage: 200...240 V 50/60 Hz							
ATV 31H018M3X	5	–	7	7	–	VW3 A31402	–
ATV 31H037M3X							
ATV 31H055M3X							
ATV 31H075M3X							
ATV 31HU11M3X	5	–	15	15	–	VW3 A31404	–
ATV 31HU15M3X							
ATV 31HU22M3X							
ATV 31HU30M3X	5	–	25	35	–	VW3 A31406	–
ATV 31HU40M3X							
ATV 31HU55M3X	5	–	47	45	–	VW3 A31407	–
ATV 31HU75M3X							
ATV 31HD11M3X	5	–	83	15	–	VW3 A31408	–
ATV 31HD15M3X							
3-phase supply voltage: 380...500 V 50/60 Hz							
ATV 31H/C/K037N4	50	20	15	15	–	VW3 A31404	–
ATV 31H/C/K055N4							
ATV 31H/C/K075N4							
ATV 31H/C/KU11N4							
ATV 31H/C/KU15N4							
ATV 31H/C/KU22N4	50	20	25	35	–	VW3 A31406	–
ATV 31H/C/KU30N4							
ATV 31H/C/KU40N4							
ATV 31H/KU55N4	50	20	47	45	–	VW3 A31407	–
ATV 31H/KU75N4							
ATV 31H/KD11N4	50	20	49	45	–	VW3 A31409	–
ATV 31H/KD15N4							

(1) The filter selection tables show the length limits for the shielded cables connecting the motors to the drives for a switching frequency of 2 to 16 kHz. These limits are given as examples only as they vary depending on the interference capacity of the motors and the cables used. If motors are connected in parallel, it is the total length that should be taken into account.

(2) In: Nominal filter current.

(3) Maximum earth leakage current at 50 Hz.

(4) By heat dissipation.

Variable speed drives for asynchronous motors

Altivar 31

Options: output filters and motor chokes

Presentation

By inserting an output filter between the drive and the motor, it is possible to:

- Limit the dv/dt at the motor terminals (500 to 1500 V/μs), for cables longer than 50 m
- Filter interference caused by opening a contactor placed between the filter and the motor
- Reduce the motor earth leakage current

When using a downstream contactor between the drive and the motor, ferrite suppressors should be fitted to each motor cable for certain drive ratings supplied with a single phase or 3-phase 200 V supply.

LR filter cell

This cell comprises 3 high frequency chokes and 3 resistors.

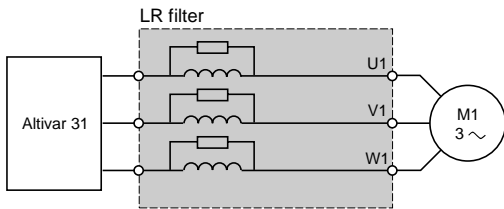

Principle

LC filter cell

This cell comprises 3 high frequency chokes and 3 capacitors.

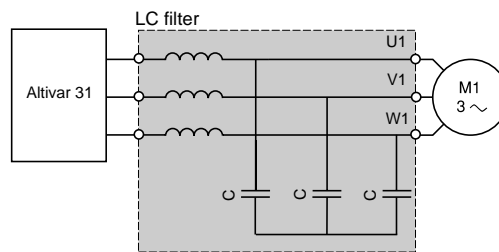

Motor choke

For standard motor cables longer than 100 m (50 m for shielded cables), a choke can be used to limit overvoltages at the motor terminals.

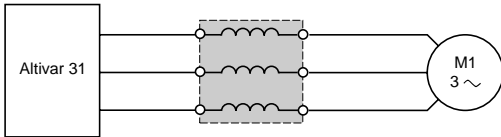

Ferrite suppressors for downstream contactor opening

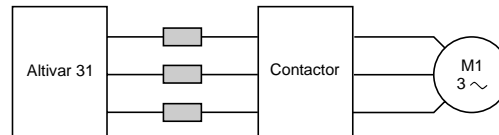

Characteristics (1)

		kHz	LR filter cells (2)		LC filter cells		Motor chokes
			VW3 A5845●	VW3 A6641●	VW3 A6641●	VW3 A6650●	
Drive switching frequency		0.5 ... 4 max.	2 or 4	12	4		
Length of motor cable	Shielded cables	m	≤ 100	≤ 100	≤ 50	≤ 100	
	Unshielded cables	m	–	≤ 200	≤ 100	–	
Degree of protection		IP 20	IP 00	IP 00	IP 20		

(1) Filter performance is ensured if the cable lengths between the motor and the drive given in the above table are not exceeded.

For an application with several motors connected in parallel, the cable length must include all tap-offs. If a cable longer than that recommended is used, the filters may overheat.

(2) Please consult your Regional Sales Office for frequencies greater than 4 kHz or cables longer than 100 m.

Variable speed drives for asynchronous motors

Altivar 31

Options: output filters and motor chokes

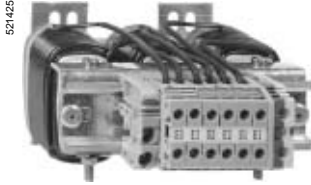

VW3 A58451

LR filter cells

For drives	Loss	Nominal current	Reference	Weight
	W	A		
ATV 31H/C/K018M2 ATV 31H/C/K037M2 ATV 31H/C/K055M2 ATV 31H/C/K075M2 ATV 31H/C/KU11M2 ATV 31H/C/KU15M2 ATV 31H018M3X ATV 31H037M3X ATV 31H055M3X ATV 31H075M3X ATV 31HU11M3X ATV 31HU15M3X ATV 31H/C/K037N4 ATV 31H/C/K055N4 ATV 31H/C/K075N4 ATV 31H/C/KU11N4 ATV 31H/C/KU15N4 ATV 31H/C/KU22N4 ATV 31H/C/KU30N4 ATV 31H/C/KU40N4 ATV 31H075S6X ATV 31HU15S6X ATV 31HU22S6X ATV 31HU40S6X ATV 31HU55S6X	150	10	VW3 A58451	7.400
ATV 31H/C/KU22M2 ATV 31HU22M3X ATV 31HU30M3X ATV 31H/KU55N4 ATV 31HU75S6X	180	16	VW3 A58452	7.400
ATV 31HU40M3X ATV 31HU55M3X ATV 31HU75M3X ATV 31H/KU75N4 ATV 31HD11S6X ATV 31HD15S6X	220	33	VW3 A58453	12.500

LC filter cells

For drives	Reference	Weight
		kg
ATV 31HD11M3X ATV 31HD15M3X	VW3 A66412	3.500

Motor chokes

For drives	Loss	Nominal current	Reference	Weight
	W	A		
ATV 31H/C/KU22N4 ATV 31H/C/KU30N4 ATV 31H/C/KU40N4 ATV 31HU40S6X, ATV 31HU55S6X	65	10	VW3 A66502	3.000
ATV 31H/C/KU22M2, ATV 31HU22M3X ATV 31HU30M3X, ATV 31H/KU55N4 ATV 31HU75S6X	75	16	VW3 A66503	3.500
ATV 31HU40M3X ATV 31HU55M3X ATV 31HU75M3X ATV 31H/KU75N4 ATV 31H/KD11N4 ATV 31HD11S6X ATV 31HD15S6X	90	30	VW3 A66504	6.000
ATV 31H/KD15N4	80	60	VW3 A66505	11.000
ATV 31HD11M3X ATV 31HD15M3X	–	100	VW3 A66506	16.000

Ferrite suppressors for downstream contactor opening

For drives	Sold in lots of	Unit reference	Weight
			kg
ATV 31H018M2	3	VW3 A31451	–
ATV 31H037M2, ATV 31H018M3 ATV 31H037M3	3	VW3 A31452	–
ATV 31H055M2, ATV 31H075M2 ATV 31HU11M2, ATV 31HU15M2 ATV 31H055M3, ATV 31H075M3	3	VW3 A31453	–

Variable speed drives for asynchronous motors

Altivar 31 Communication options

Modbus and CANopen communication buses

The Altivar 31 can be connected directly to Modbus and CANopen buses by means of an RJ45 connector, which supports both protocols. The communication function provides access to the drive's configuration, adjustment, control and monitoring functions.

CANopen

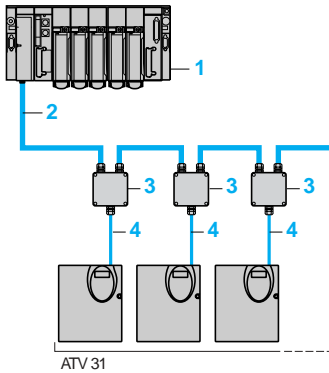

- 1 PLC (1)
- 2 CANopen trunk cable
- 3 CANopen tap junction **VW3 CAN TAP2**
- 4 CANopen drop cable **VW3 CAN CA RR●●**

Modbus

Connections via splitter blocks and RJ45 connectors

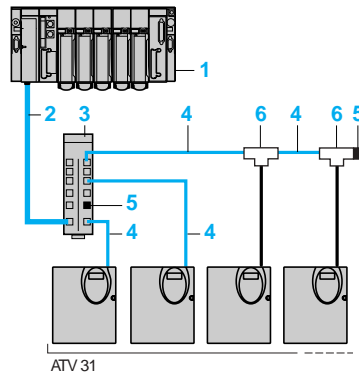

- 1 PLC (1)
- 2 Modbus cable depending on the type of controller or PLC
- 3 Modbus splitter block **LU9 GC3**
- 4 Modbus drop cables **VW3 A8 306 R●●**
- 5 Line terminators **VW3 A8 306 RC**
- 6 Modbus T-junction boxes **VW3 A8 306 TF●●** (with cable)

Connections via junction boxes

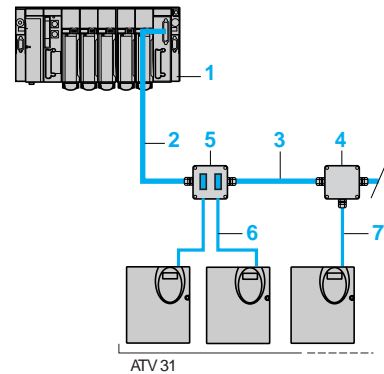

- 1 PLC (1)
- 2 Modbus cable depending on the type of controller or PLC
- 3 Modbus cables **TSX CSA●00**
- 4 T-junction box **TSX SCA 50**
- 5 Subscriber socket **TSX SCA 62**
- 6 Modbus drop cables **VW3 A8 306**
- 7 Modbus drop cables **VW3 A8 306 D30**

Connections via screw terminals

In this case, use a Modbus drop cable **VW3 A8 306 D30** and line terminators **VW3 A8 306 DRC**.

Other communication buses

The Altivar 31 can also be connected to the following networks via a module (bridge or gateway):

- Ethernet
- Fipio
- Profibus DP
- DeviceNet

The communication function provides access to the drive's configuration, adjustment, control and monitoring functions.

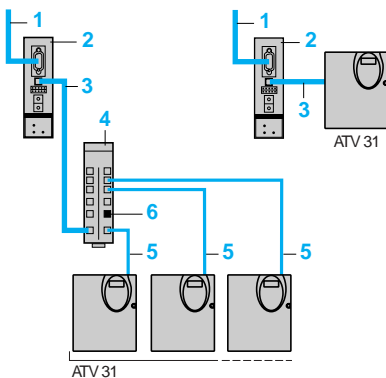

- 1 To network
- 2 Communication modules
- 3 Cables **VW3 A8 306 R●●**, **VW3 P07 306 R10** or **VW3 A8 306 D30**, depending on the type of module.
- 4 Modbus splitter block **LU9 GC3**
- 5 Modbus drop cables **VW3 A8 306 R●●**
- 6 Line terminator **VW3 A8 306 RC**

(1) Please consult our specialist catalogues.

Variable speed drives for asynchronous motors

Altivar 31

Communication options



TSX SCA 50



TSX SCA 62



174 CEV 300 20



LUF P1



LA9 P307

Modbus and CANopen communication buses

Connection accessories

Description	Reference	Weight kg	
CANopen bus junction box	VW3 CAN TAP2	–	
Modbus junction box 3 screw terminals, RC line terminator To be connected using cable VW3 A8 306 D30	TSX SCA 50	0.520	
Modbus subscriber socket 2 female 15-way SUB-D connectors and 2 screw terminals, RC line terminator To be connected using cable VW3 A8 306	TSX SCA 62	0.570	
Modbus splitter block 10 RJ45 connectors and 1 screw terminal	LU9 GC3	0.500	
Modbus line terminators (1)	For RJ45 connector R = 120 Ω, C = 1 nF	VW3 A8 306 RC	0.200
	R = 150 Ω	VW3 A8 306 R	0.200
	For screw terminals R = 120 Ω, C = 1 nF	VW3 A8 306 DRC	0.200
	R = 150 Ω	VW3 A8 306 DR	0.200
Modbus T-junction boxes	With integrated cable (0.3 m)	VW3 A8 306 TF03	–
	With integrated cable (1 m)	VW3 A8 306 TF10	–

Connecting cables

Description	Length m	Connectors	Reference	Weight kg
Cables for CANopen bus	0.3 m	2 RJ45 connectors	VW3 CAN CA RR03	0.050
	10 m	2 RJ45 connectors	VW3 CAN CA RR1	0.500
Cables for Modbus bus	3	1 RJ45 connector and one end stripped	VW3 A8 306 D30	0.150
	3	1 RJ45 connector and 1 male 15-way SUB-D connector for TSX SCA 62	VW3 A8 306	0.150
	0.3	2 RJ45 connectors	VW3 A8 306 R03	0.050
	1	2 RJ45 connectors	VW3 A8 306 R10	0.050
	3	2 RJ45 connectors	VW3 A8 306 R30	0.150
	1	2 RJ45 connectors	VW3 P07 306 R10	0.050
Cables for Profibus gateway LA9 P307				
RS 485 double shielded twisted pair cables	100	Supplied without connector	TSX CSA 100	–
	200	Supplied without connector	TSX CSA 200	–
	500	Supplied without connector	TSX CSA 500	–

Other communication buses

Description	Cables to be connected	Reference	Weight kg
Ethernet/Modbus bridge with 1 x Ethernet 10baseT port (RJ45)	VW3 A8 306 D30	174 CEV 300 20 (2)	0.500
Fipio/Modbus gateway (3)	VW3 A8 306 R●●	LUF P1	0.240
DeviceNet/Modbus gateway (3)	VW3 A8 306 R●●	LUF P9	0.240
Profibus DP/Modbus gateway Parameters set using standard Profibus DP configurator (3)	VW3 P07 306 R10	LA9 P307	0.240
Profibus DP/Modbus gateway Parameters set using ABC Configurator software (3)	VW3 A8 306 R●●	LUF P7	0.240

(1) Sold in lots of 2.

(2) Please consult our catalogue "Premium automation platform".

(3) Please consult our catalogue "Soft starters and variable speed drives".

The PowerSuite software workshop, for PC or Pocket PC, is designed for setting up Telemecanique starters and variable speed drives.

This single program is an easy-to-use interface for configuring Altistart and Tesys model U starters and all Altivar drives in a Microsoft Windows® environment in five languages (English, French, German, Italian and Spanish).

Functions

The PowerSuite software workshop can be used for preparing, programming, setting up and maintaining Telemecanique starters and variable speed drives.

It can be used:

- stand alone to prepare and store starter or drive configuration files
- connected to the starter or drive to:
 - configure
 - adjust
 - monitor (except for Altivar 11 drives)
 - control (except for Altivar 11 drives)
 - transfer and compare configuration files between PowerSuite and the starter or drive

The software workshop has online contextual help.

PowerSuite can be used to generate configuration files which can then be:

- saved to hard disk, CD-ROM, floppy disk, etc.
- printed
- exported to office automation software
- exchanged between a PC and a Pocket PC using standard synchronization software. PowerSuite PC and Pocket PC configuration files are both the same format.

The software associated with the Altivar 31 has been enhanced to include the following new functions:

oscilloscope function, parameter name customization, configuration locking using a password, creation of a user menu, etc.

Connections

Telemecanique starters and variable speed drives are equipped with a Modbus RS485 terminal port (except for Altivar 68 drives).

- The PowerSuite software workshop can be connected directly to the terminal port via the serial port on the PC or Pocket PC.

Two types of connection are possible:

- connection to a single starter or drive (point-to-point connection)
- connection to a set of starters or drives (multidrop connection)

- The PowerSuite for PC software workshop can also be connected to an Ethernet network (Please consult our catalogue "Soft starters and variable speed drives). In this case, the starters and drives can be accessed:

- using an Ethernet-Modbus bridge 174 CEV 300 20
- using a communication option card VW3 A58310 (for Altivar 38, 58 and 58F drives only)

Hardware and software environment

- The PowerSuite for PC software workshop can operate in the following PC environments and configurations:

- Microsoft Windows® 95 OSR2-98 SE, Microsoft Windows® NT4.X SP5, Microsoft Windows® Me, Microsoft Windows® 2000, Microsoft Windows® XP
- Pentium III, 800 MHz, hard disk with 300 MB available, 128 MB RAM
- SVGA or higher definition monitor

- The PowerSuite for Pocket PC software workshop is compatible with Pocket PCs equipped with a Windows for Pocket PC 2002 operating system and an ARM or XSCALE processor.

Performance tests for version V2.0.0 of the PowerSuite software workshop have been carried out on the following Pocket PCs:

- Hewlett Packard® Jornada series 560
- Compaq® IPAQ series 3800 and 3900

531439

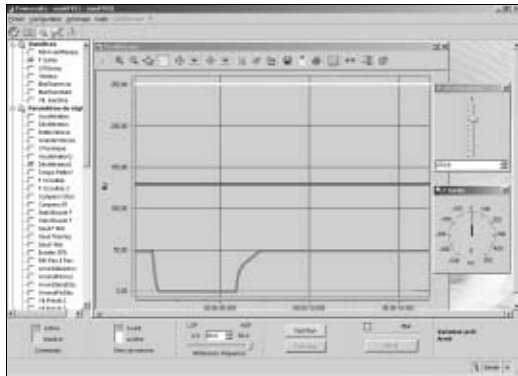

PowerSuite with PC screen
Oscilloscope function

531440

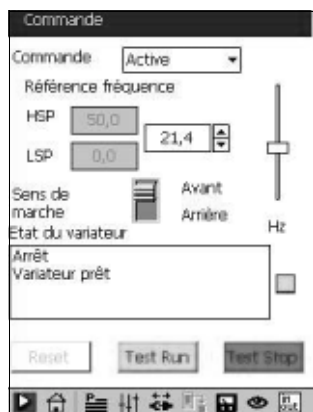

PowerSuite with Pocket PC screen

PowerSuite software workshop



VW3 A8101

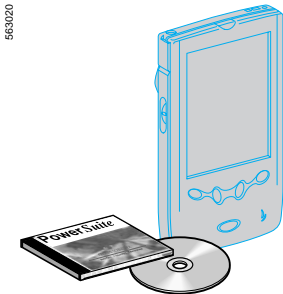

VW3 A8102

PowerSuite software workshop for PC and Pocket PC

Description	Reference	Weight kg
PowerSuite for PC kit comprising: - 1 PowerSuite CD-ROM - 1 PC connection kit	VW3 A8101	0.400
PowerSuite for Pocket PC kit comprising: - 1 PowerSuite CD-ROM - 1 Pocket PC connection kit	VW3 A8102	0.400
PowerSuite CD-ROM - Contains the software for PC and Pocket PC in English, French, German, Italian and Spanish along with the technical documentation and the ABC configurator program.	VW3 A8104	0.100
PowerSuite upgrade CD-ROM - Contains the software for PC and Pocket PC in English, French, German, Italian and Spanish along with the technical documentation and the ABC configurator program.	VW3 A8105	0.100
PC connection kit comprising: - 2 x 3 m connecting cables with 2 x RJ 45 connectors - 1 RJ 45/9-way SUB-D adaptor for connecting ATV 58, ATV 58F and ATV 38 drives - 1 RJ 45/9-way SUB-D adaptor for connecting ATV 68 drives - 1 converter marked "RS 232/RS 485 PC" with one 9-way female SUB-D connector and 1 RJ 45 connector - 1 converter, for ATV 11 drives, with one 4-way male connector and 1 RJ 45 connector	VW3 A8106	0.350
Pocket PC connection kit comprising: - 2 x 0.6 m connecting cables with 2 x RJ 45 connectors - 1 RJ 45/9-way SUB-D adaptor for connecting ATV 58, ATV 58F and ATV 38 drives - 1 converter marked "RS 232/RS 485 PPC" with one 9-way male SUB-D connector and 1 RJ 45 connector - 1 converter, for ATV 11 drives, with one 4-way male connector and 1 RJ 45 connector	VW3 A8111	0.300

Caution: The serial synchronization cable must be ordered separately from the supplier of the Pocket PC.

(1) To find out about the latest available version, please consult your Regional Sales Office.

Compatibility

Compatibility of the PowerSuite software workshop with the starters and variable speed drives

Controller starter	Soft start/soft stop unit	Drives						
		TeSys model U	ATS 48	ATV 11	ATV28	ATV 31	ATV 38	ATV 58, ATV 58F

PowerSuite software workshop with serial link for PC

Kit and CD-ROM	VW3 A8101, VW3 A8104, VW3 A8105	≥ V 1.40	≥ V 1.30	≥ V 1.40	≥ V 1.0	≥ V 2.0.0	≥ V 1.40	≥ V 1.0	≥ V 1.50
----------------	---------------------------------	----------	----------	----------	---------	-----------	----------	---------	----------

PowerSuite software workshop with Ethernet link for PC

Kit and CD-ROM	VW3 A8101, VW3 A8104, VW3 A8105	–	≥ V 1.50 and Ethernet/Modbus bridge	–	≥ V 1.50 and Ethernet-Modbus bridge	≥ V 2.0.0 and Ethernet/Modbus bridge	≥ V 1.50 and Ethernet V2 communication card or bridge	–	–
----------------	---------------------------------	---	-------------------------------------	---	-------------------------------------	--------------------------------------	---	---	---

PowerSuite software workshop for Pocket PC

Kit and CD-ROM	VW3 A8102, VW3 A8104, VW3 A8105	≥ V 1.50	≥ V 1.30	≥ V 1.40	≥ V 1.20	≥ V 2.0.0	≥ V 1.40	≥ V 1.20	–
----------------	---------------------------------	----------	----------	----------	----------	-----------	----------	----------	---

Incompatible products

Compatible products and software versions

Compatibility of the PowerSuite software workshop with Pocket PCs

Pocket PC	PowerSuite software version
Hewlett Packard® Jornada 525, 545, 548	not compatible from V 2.0.0
Hewlett Packard® Jornada series 560	≥ 1.30
Compaq® IPAQ series 3800 and 3900	≥ 1.30

Variable speed drives for asynchronous motors

Altivar 31

ATV 31H0●●M3X/MXA, ATV 31H0●●M2/M2A

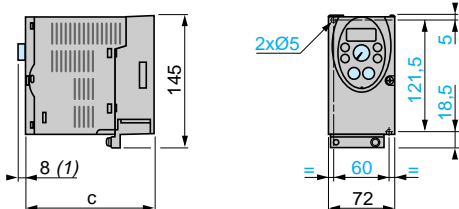

ATV 31H	c
018M3X, 037M3X	120
055M3X, 075M3X	130
018M2, 037M2	130
055M2, 075M2	140

Plate for EMC mounting
(supplied with the drive)

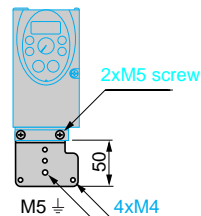

(1) Only for drives whose reference ends in A.

ATV 31HU●●M2/M2A, ATV 31HU1●M3X/M3XA to ATV 31HU4●M3X/M3XA, ATV 31H0●●N4/N4A to ATV 31HU40N4/N4A, ATV 31H075S6X to ATV 31HU40S6X

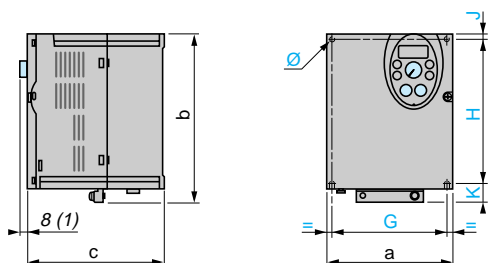

ATV 31H	a	b	c	d	G	H	J	K	Ø
U1●M3X	105	143	130	49	93	121.5	5	16.5	2x5
U1●M2, U22M3X 037N4 to U15N4 U75S6X, U15S6X	105	143	150	49	93	121.5	5	16.5	2x5
U22M2, HU●0M3X U22N4 to U40N4 U22S6X, U40S6X	140	184	150	48	126	157	6.5	20.5	4x5

Plate for EMC mounting
(supplied with the drive)

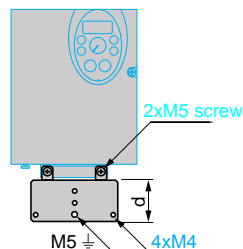

(1) Only for drives whose reference ends in A.

ATV 31HU55M3X/M3XA, ATV 31HU75M3X/M3XA, ATV 31HU55N4/N4A, ATV 31HU75N4/N4A, ATV 31HU55S6X, ATV 31HU75S6X

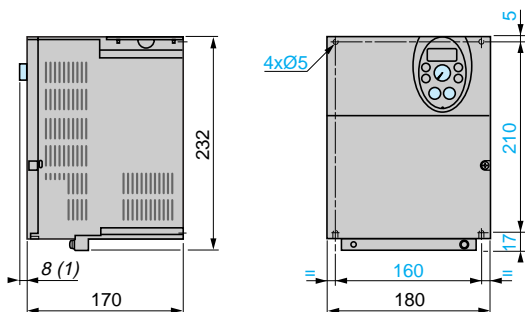
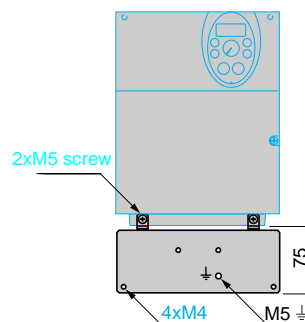

Plate for EMC mounting
(supplied with the drive)



(1) Only for drives whose reference ends in A.

ATV 31HD1●M3X/M3XA, ATV 31HD1●N4/N4A, ATV 31HD1●S6X

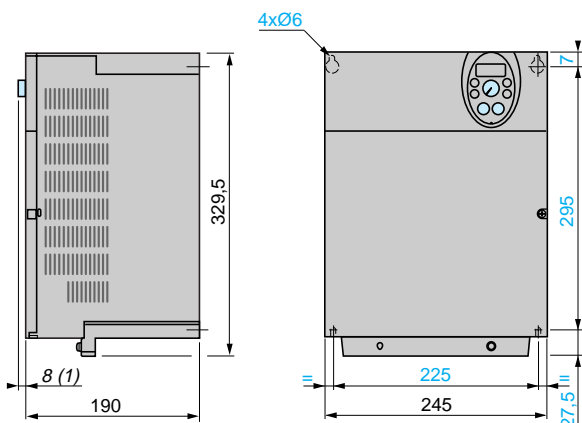
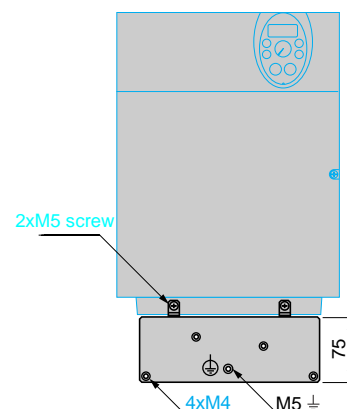
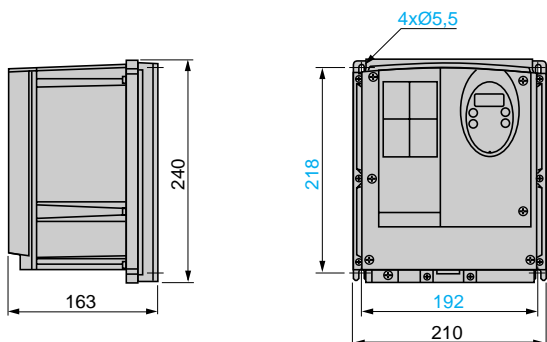

Plate for EMC mounting
(supplied with the drive)



(1) Only for drives whose reference ends in A.

ATV 31C0●●M2



ATV 31CU11M2, ATV 31CU15M2, ATV 31C0●●N4, ATV 31CU11N4, ATV 31CU15N4

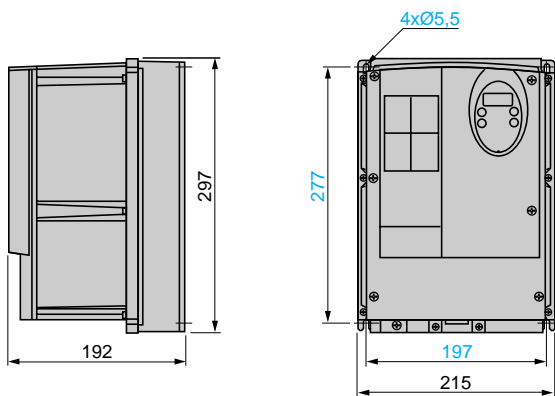

ATV 31CU22M2, ATV 31CU22N4, ATV 31CU30N4, ATV 31CU40N4

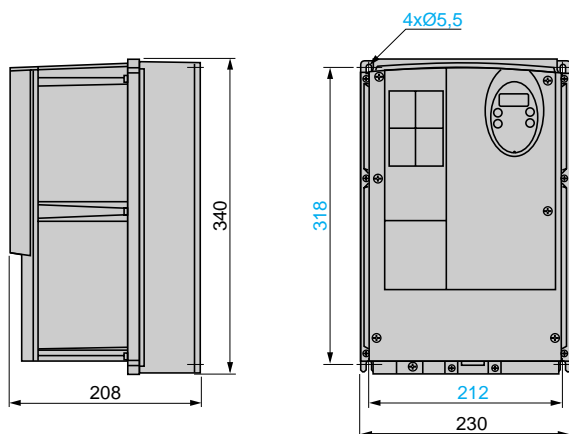

Variable speed drives for asynchronous motors

Altivar 31
Drive kit

ATV 31K00M2, ATV 31K00N4, ATV 31KU22N4, ATV 31KU00N4

Mounting

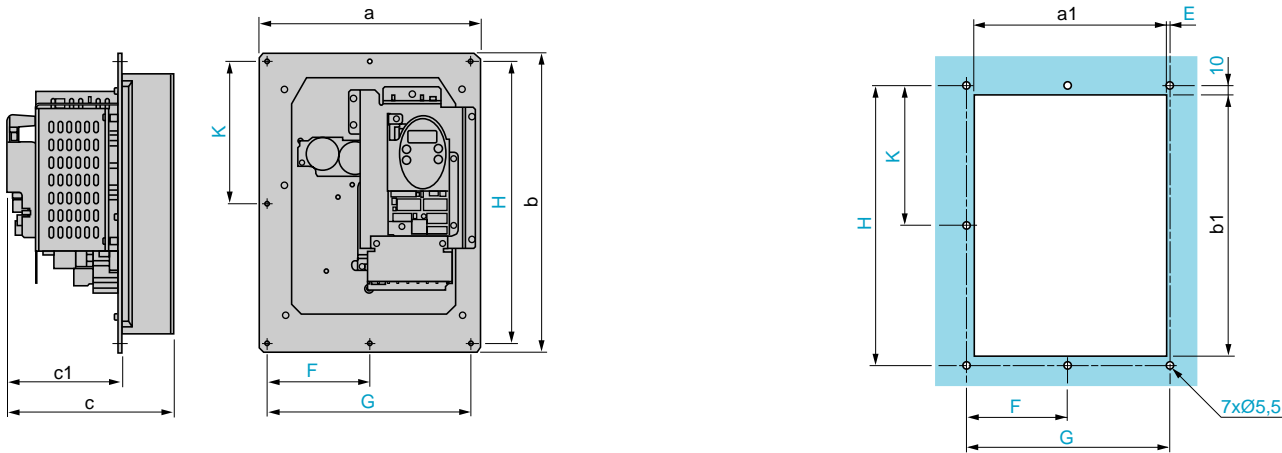

ATV 31K	a	a1	b	b1	c	c1	E	F	G	H	K
00M2	254	214	280	240	153	123	10	117	234	260	130
U1M2, 00N4, U1N4	250	219	337	297	186	127	1	115	230	317	158.5
U22M2, U00N4	265	234	380	340	209	134	1	122.5	245	360	180

Note: product supplied with drilling template.

ATV 31KU55N4, ATV 31KU75N4, ATV 31KD10N4/0M2

Mounting

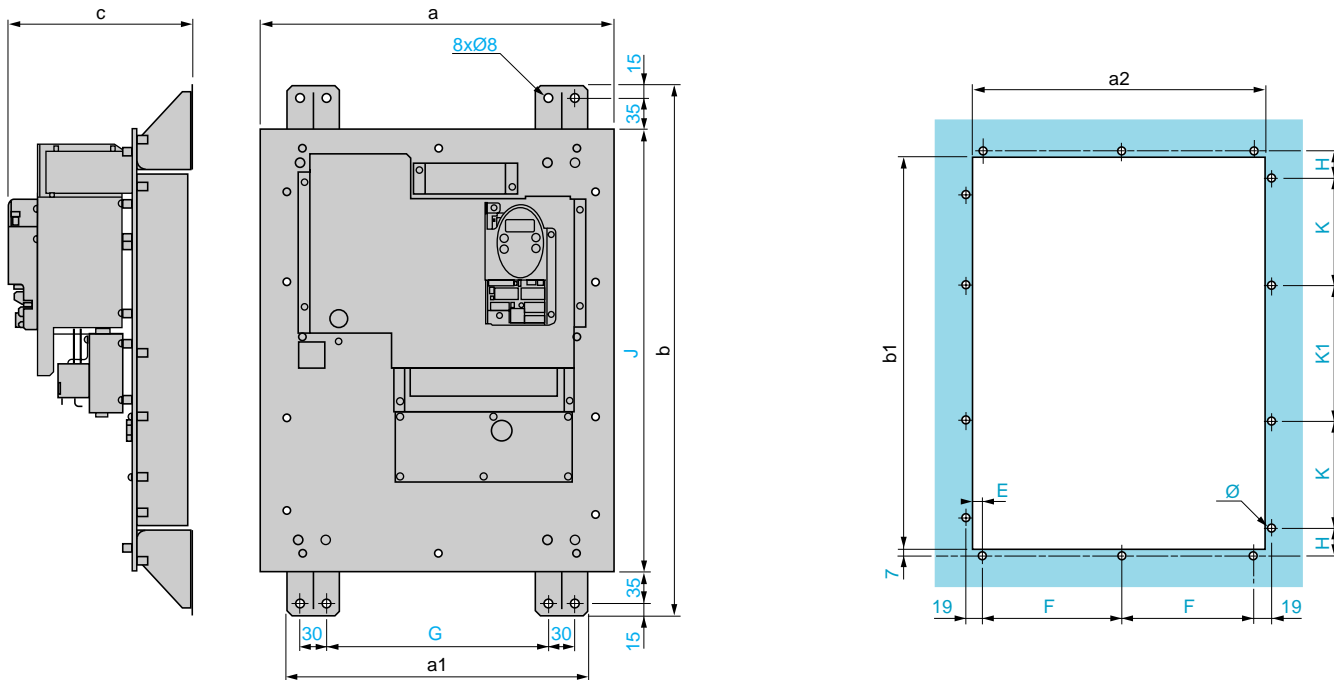

ATV 31K	a	a1	a2	b	b1	c	E	F	G	H	J	K	K1	Ø
U55N4, U75N4	400	340	334	600	444	343	12	155	250	49	500	180	0	12 x 6
D11N4, D15N4	450	370	386	700	546	267	13	180	280	39	600	150	180	14 x 6

Note: product supplied with drilling template.

Plates for mounting on rail

VW3 A11851

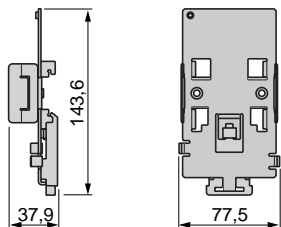

VW3 A31852

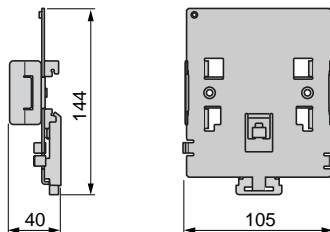

UL NEMA Type 1 conformity kit

VW3 A31811 to VW3 A31817

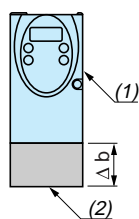

VW3	Δb
A31812	77
A31813 and A31814	107
A31815	138
A31816	179
A31817	244

(1) Drive

(2) Kit for VW3 A3181●

Remote terminal

VW3 A31101

Mounting

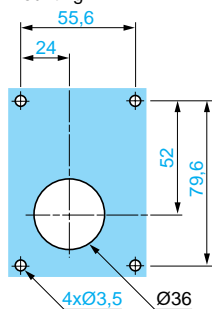

Bare braking resistors

VW3 A58702 and A58704

2-wire output, length 0.5 m

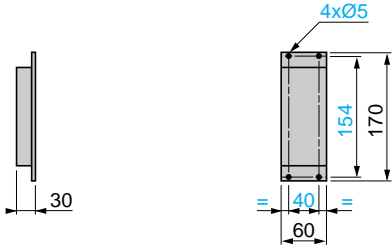

VW3 A58703

2-wire output, length 0.5 m

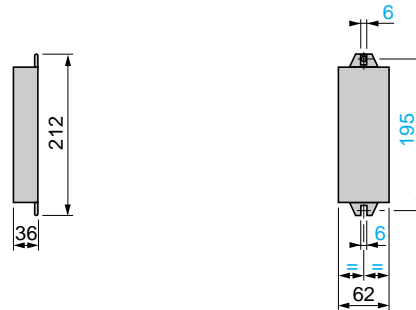

Protected braking resistors

VW3 A58732 to VW3 A58734

VW3 A58735 to VW3 A58737

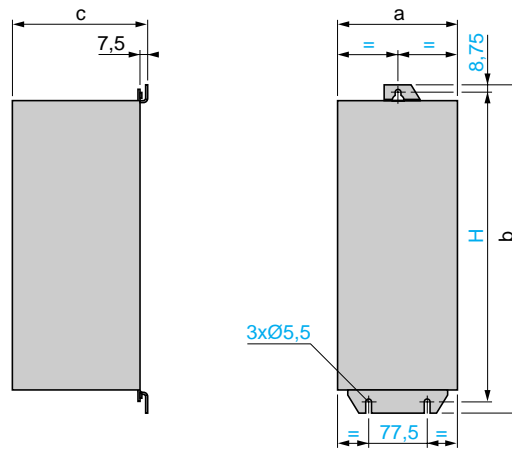
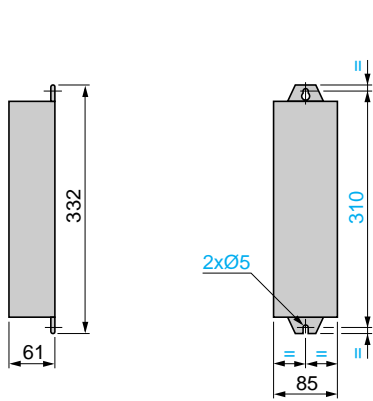

VW3	a	b	c	H
A58735	163	340	61	320
A58736, A58737	156	434	167	415

VW3 A66704

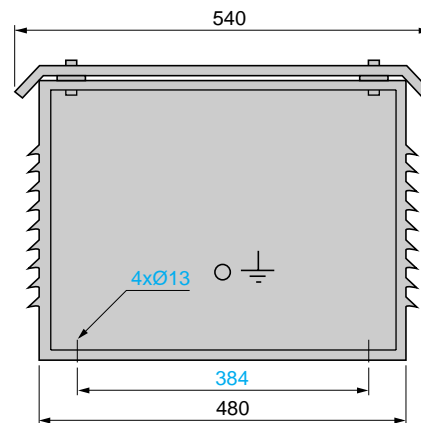
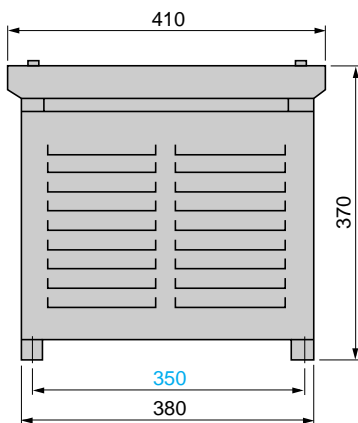

Single phase chokes

VZ1 L●●●●●●●●

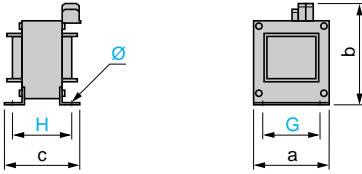

VZ1	a	b	c	G	H	Ø
L004M010	60	100	80	50	44	4 x 9
L007UM50	60	100	95	50	60	4 x 9
L018UM20	85	120	105	70	70	5 x 11

3-phase chokes

VW3 A66501 to VW3 A66506

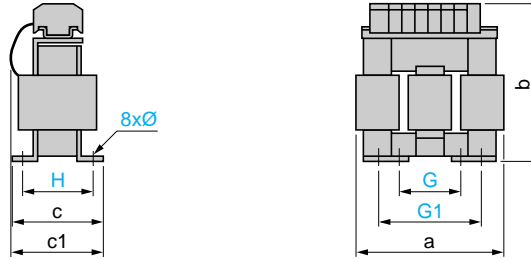

VW3	a	b	c	c1	G	G1	H	Ø
A66501	100	135	55	60	40	60	42	6 x 9
A66502	130	155	85	90	60	80.5	62	6 x 12
A66503	130	155	85	90	60	80.5	62	6 x 12
A66504	155	170	115	135	75	107	90	6 x 12
A66505	180	210	125	165	85	122	105	6 x 12
A66506	275	210	130	160	105	181	100	11 x 22

Additional EMC input filters:

Mounting of filter underneath the drive

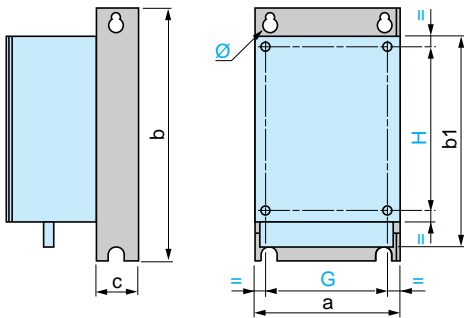

Mounting of filter adjacent to drive

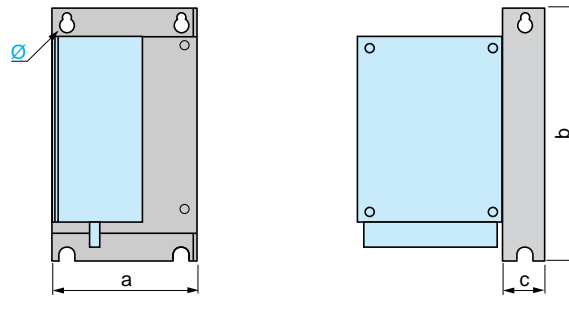

VW3	a	b	b1	c	G	H	Ø
A31401, A31402	72	185	—	50	60	121.5	2 x M4
A31403, A31404	105	185	—	60	93	121.5	2 x M4
A31405, A31406	140	225	—	60	126	157	4 x M4
A31407	180	275	—	60	160	210	4 x M4
A31408, A31409	245	365	—	60	295	225	4 x M5

Output filters

VW3 A58451 to VW3 A58453

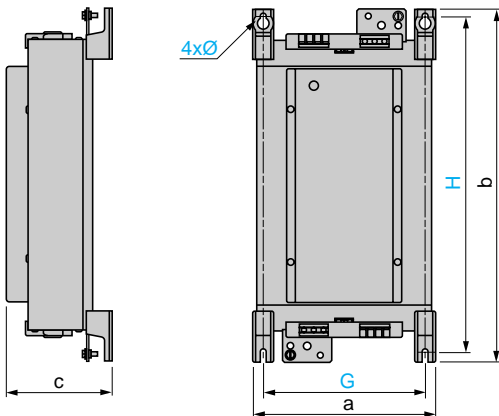

VW3	a	b	c	G	H	Ø
A58451	169.5	340	123	150	315	7
A58452						
A58453	239	467.5	139.5	212	444	7

Ferrite suppressors for downstream contactor opening

VW3 A31451 to VW3 A31452

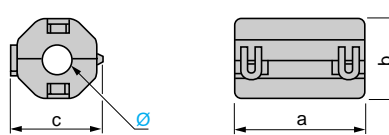

VW3	a	b	c	Ø
A31451	33.5	33	33	13
A31452	33	21.5	22.5	9
A31453	30	19	19	6

ATV 31●●●●M3X, ATV 31●●●●N4, ATV 31●●●●S6X

3-phase power supply

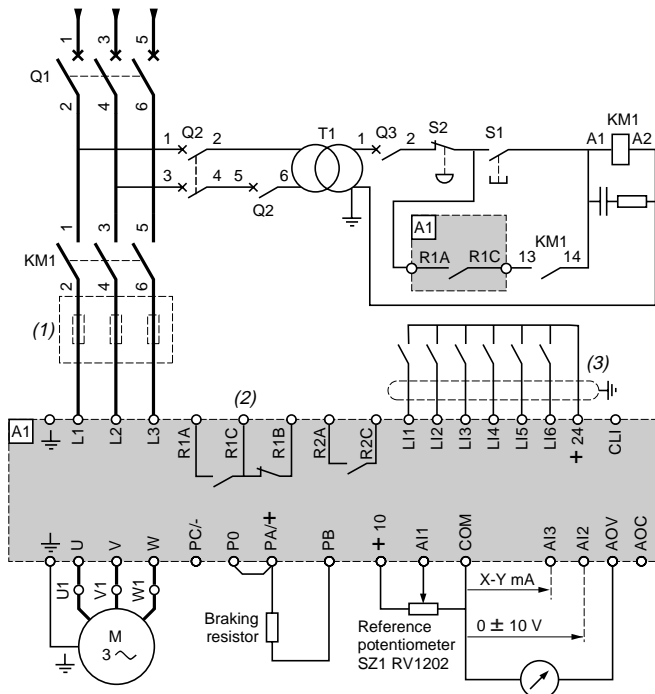

ATV 31●●●●M2

Single phase power supply

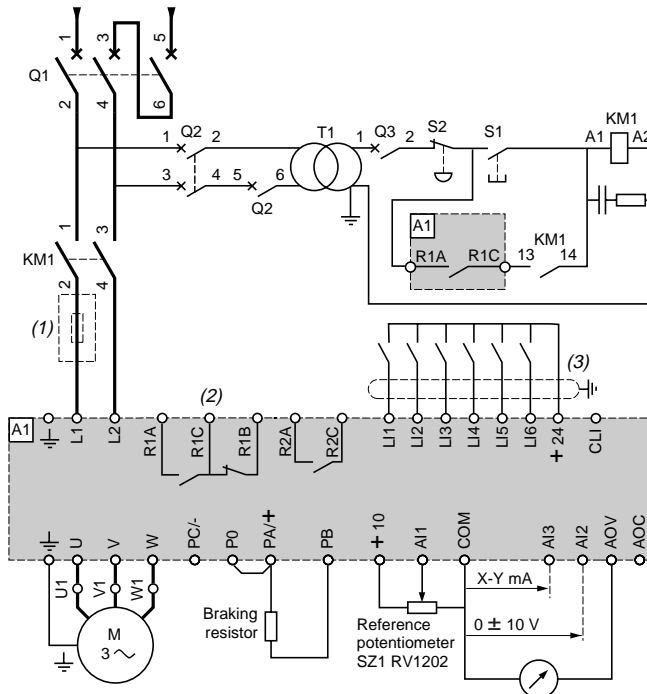

- (1) Line choke (single phase or 3-phase).
- (2) Fault relay contacts. For remote signalling of drive status.
- (3) Shared connection of the logic inputs depends on the position of a switch, see diagrams below.

Note: All terminals are located at the bottom of the drive.

Fit interference suppressors to all inductive circuits near the drive or connected on the same circuit, such as relays, contactors, solenoid valves, fluorescent lighting, etc.

Compatible components (for full references, please consult our specialist catalogue).

Code	Description
Q1	GV2 L or Compact NS (see pages 40 to 43)
KM1	LC1 ●●● + LA4 DA2U (see pages 40 to 43)
S1, S2	XB2 B or XA2 B pushbuttons
T1	100 VA transformer 220 V secondary
Q2	GV2 L rated at twice the nominal primary current of T1
Q2	GB2 CB05

Examples of recommended circuit diagrams

Logic input switches

"Source" position

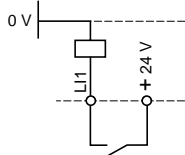

"Sink" position

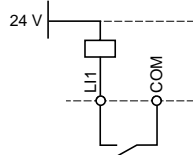

CLI position with PLC transistor outputs

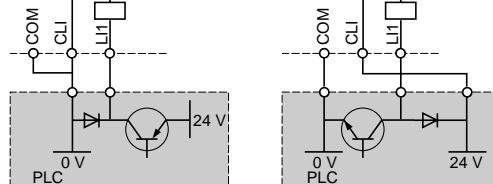

AOC output

Wired as logic output

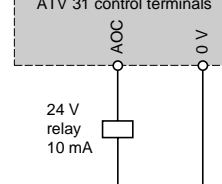

2-wire control

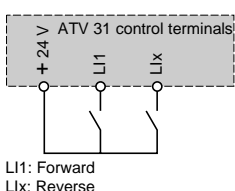

L11: Forward
L1x: Reverse

3-wire control

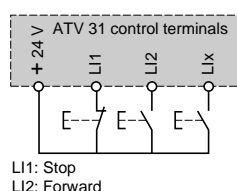

L11: Stop
L12: Forward
L1x: Reverse

Analog voltage inputs

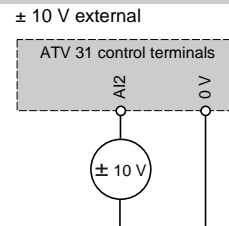
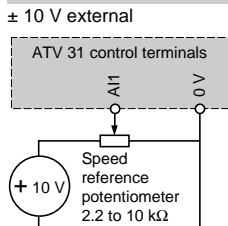

Analog current input

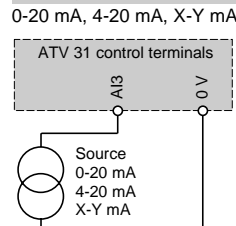

Schemes

Additional radio interference suppression input filters VW3 A3140●

3-phase power supply

Single phase power supply

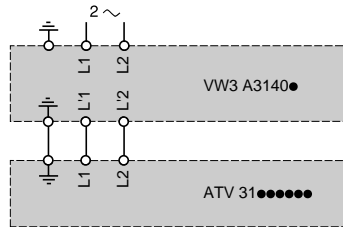
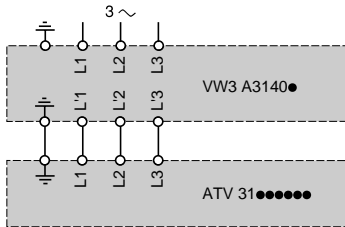

Connections to meet the requirements of EMC standards

Principle

- Grounds between the drive, motor and cable shielding must have "high frequency" equipotentiality.
- Use shielded cables with the shielding connected to ground throughout 360° at both ends for the motor cable, the braking resistor cable and the control/command cables. Metal ducting or conduit can be used for part of the shielding length provided that there is no break in continuity.
- Ensure maximum separation between the power supply cable (line supply) and the motor cable.

Installation diagram for ATV 31H●● drives

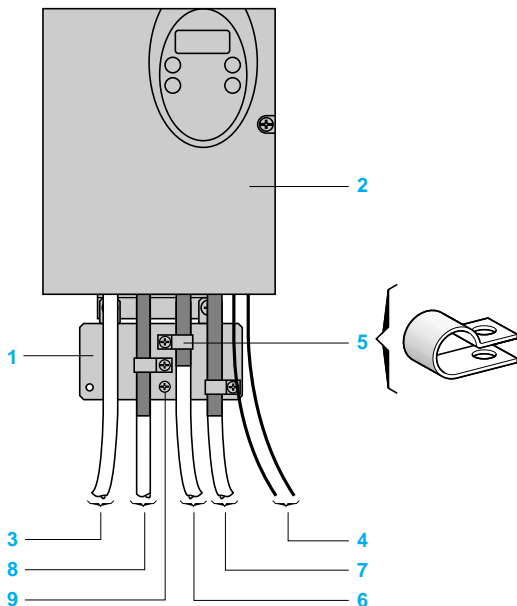

- 1 Steel plate supplied with the drive, to be fitted on it (machine ground)
- 2 Altivar 31
- 3 Non-shielded power supply wires or cable
- 4 Non-shielded wires for the output of the safety relay contacts.
- 5 Fix and ground the shielding of cables 6, 7 and 8 as close as possible to the drive:
 - Strip the shielding.
 - Use cable clamps of an appropriate size on the parts from which the shielding has been stripped, to attach them to the plate 1.
 The shielding must be clamped tightly enough to the metal plate to ensure good contact.
Cable clamps must be made from stainless steel.
- 6 Shielded cable for connecting the motor.
- 7 Shielded cable for connecting the control/command wiring. For applications requiring several conductors, use cables with a small cross-section (0.5 mm²).
- 8 Shielded cable for connecting the braking resistor.
- 6, 7, 8, the shielding must be connected to ground at both ends. The shielding must be continuous and intermediate terminals must be in EMC shielded metal cases.
- 9 Ground screw for the motor cable with low ratings, as the screw on the heatsink is inaccessible.

Note: The HF equipotential ground connection between the drive, motor and cable shielding does not remove the need to connect the PE protective conductors (green-yellow) to the appropriate terminals on each unit.
If using an additional input filter, it should be mounted beneath the drive and connected directly to the line supply via an unshielded cable. Link 3 on the drive is then via the filter output cable.

Operation on an IT system

IT system: isolated or impedance earthed neutral.

Use a permanent insulation monitor compatible with non-linear loads, e.g. Merlin Gerin type XM200.

ATV 31●●M2 and N4 drives feature built-in RFI filters. There are two ways of isolating these filters from ground for operation on an IT system:

- ATV 31H018M2 to ATV 31HU22M2 and ATV 31H037N4 to ATV 31HU40N4, pull out a jumper to disconnect the filter.
- ATV 31HU55N4 to ATV 31HD15N4, move the cable tag to disconnect the filter.

Depending on the conditions in which the drive is to be used, its installation will require certain precautions and the use of appropriate accessories.

Mounting recommendations for ATV 31H drives

Install the unit vertically, at $\pm 10^\circ$.

- Do not place it close to heating elements.
- Leave sufficient free space to ensure that the air required for cooling purposes can circulate from the bottom to the top of the unit.

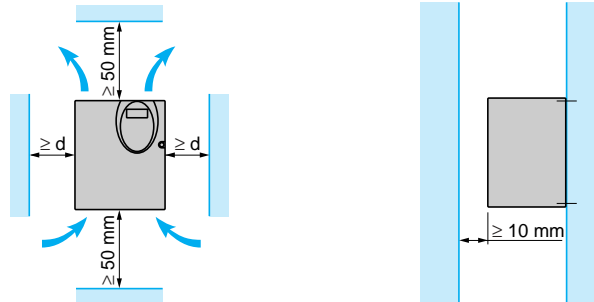

Types of mounting

■ Type A mounting

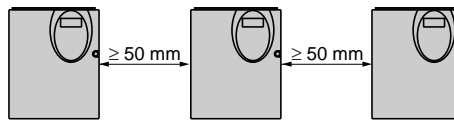

■ Type B mounting

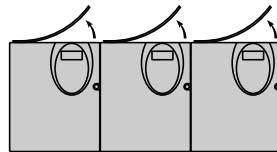

■ Type C mounting

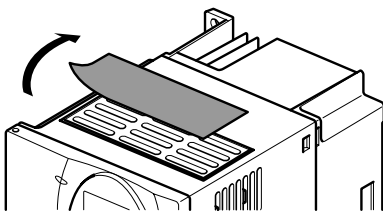
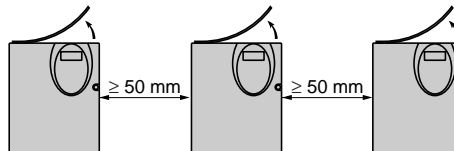

Removing the protective cover

Removing the protective cover from the top of the drive (as shown opposite) changes the degree of protection to IP 20.

Derating curves for the nominal drive current (I_n) as a function of the temperature, switching frequency and type of mounting.

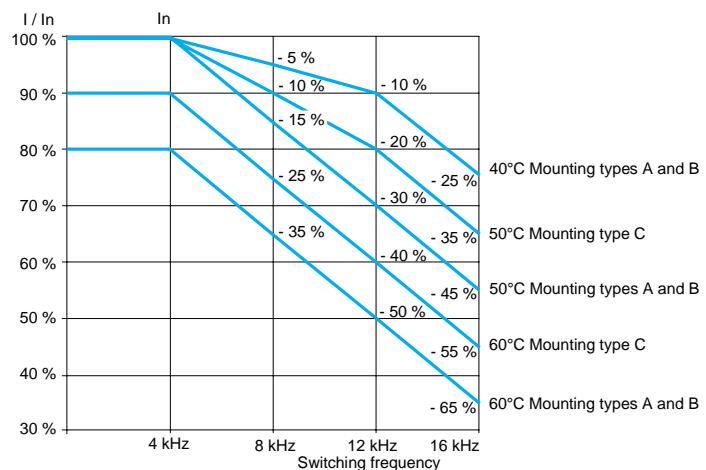

For intermediate temperatures (e.g. 55°C), interpolate between 2 curves.

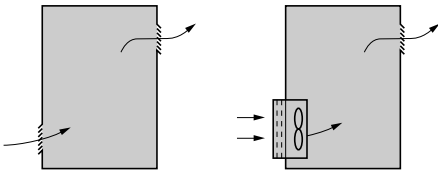

Specific recommendations for mounting ATV 31 drives in a wall-mounted or floor-standing enclosure

Observe the mounting recommendations on the opposite page.

To ensure proper air circulation in the drive:

- Fit ventilation grilles.
- Ensure that there is sufficient ventilation. If there is not, install forced ventilation with a filter. The openings and/or fans must provide a flow rate at least equal to that of the drive fans (see the table below).
- Use special filters with IP 54 protection.
- Remove the protective cover from the top of the drive.

Fan flow rate depending on the drive rating

ATV 31 drive	Flow rate m ³ /min
H018M2, H037M2, H055M2, H018M3X, H037M3X, H055M3X, H037N4, H055N4, H075N4, HU11N4, H075S6X, HU15N6X	0.3
H075M2, HU11M2, HU15M2, H075M3X, HU11M3X, HU15M3X, HU15N4, HU22N4, HU22S6X, HU40N6X	0.55
HU22M2, HU22M3X, HU30M3X, HU40M3X, HU30N4, HU40N4, HU55S6X, HU75S6X	1.55
HU55M3X, HU55N4, HU75N4, HD11S6X	1.7
HU75M3X, HD11M3X, HD11N4, HD15N4, HD15S6X	2.8
HD15M3X	3.6

Dust and damp proof metal wall-mounted or floor-standing enclosure (IP 54 degree of protection)

The drive must be mounted in a dust and damp proof enclosure in certain environmental conditions: dust, corrosive gases, high humidity with risk of condensation and dripping water, splashing liquid, etc.

This enables the drive to be used in an enclosure where the maximum internal temperature can reach 50°C.

Calculating the size of the enclosure

Maximum thermal resistance R_{th} (°C/W)

$$R_{th} = \frac{\theta^{\circ} - \theta_e}{P}$$

θ = maximum temperature inside enclosure in °C
 θ_e = maximum external temperature in °C
 P = total power dissipated in the enclosure in W

Power dissipated by drive: see page 14.

Add the power dissipated by the other equipment components.

Useful heat dissipation surface of enclosure S (m²)

(sides + top + front panel if wall-mounted)

$$S = \frac{k}{R_{th}}$$

K = thermal resistance per m² of enclosure.

For metal enclosures: K = 0.12 with internal fan, K = 0.15 without fan

Note: Do not use insulated enclosures as they have a poor level of conductivity.

Mounting recommendations for ATV 31 drives

Install the unit vertically, at ± 10°.

Do not place it close to heating elements.

Leave sufficient free space to ensure that the air required for cooling purposes can circulate from the bottom to the top of the unit.

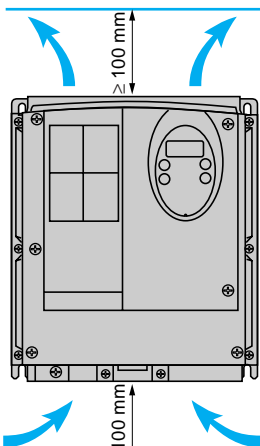

Variable speed drives for asynchronous motors

Altivar 31 Motor starters

Applications

The combinations suggested below can be used to assemble a complete motor starter comprising a circuit-breaker, a contactor and an Altivar 31 variable speed drive.

The circuit-breaker provides protection against accidental short-circuits, isolation, and padlocking if required.

The contactor provides control and management of any safety features and isolation of the motor on stopping.

The Altivar 31 variable speed drive is electronically protected against short-circuits between phases and between phase and earth; it therefore provides continuity of service and thermal protection of the motor.

Motor starter for drive with heatsink

Variable speed drive Reference	Standard power rating of 4-pole 50/60 Hz motors (1)		Circuit-breaker (2)		Max. prosp. line Isc	Contactor (3) Add the voltage number to the basic reference to obtain the full reference (4)
	kW	HP	Reference	Rating		
Single phase supply voltage: 200...240 V						
ATV 31H018M2	0.18	0.25	GV2 L08	4	1	LC1 K0610
ATV 31H037M2	0.37	0.5	GV2 L10	6.3	1	LC1 K0610
ATV 31H055M2	0.55	0.75	GV2 L14	10	1	LC1 K0610
ATV 31H075M2	0.75	1	GV2 L14	10	1	LC1 K0610
ATV 31HU11M2	1.1	1.5	GV2 L16	14	1	LC1 K0610
ATV 31HU15M2	1.5	2	GV2 L20	18	1	LC1 K0610
ATV 31HU22M2	2.2	3	GV2 L22	25	1	LC1 D09
3-phase supply voltage: 200...240 V						
ATV 31H018M3X	0.18	0.25	GV2 L07	2.5	5	LC1 K0610
ATV 31H037M3X	0.37	0.5	GV2 L08	4	5	LC1 K0610
ATV 31H055M3X	0.55	0.75	GV2 L10	6.3	5	LC1 K0610
ATV 31H075M3X	0.75	1	GV2 L14	10	5	LC1 K0610
ATV 31HU11M3X	1.1	1.5	GV2 L14	10	5	LC1 K0610
ATV 31HU15M3X	1.5	2	GV2 L16	14	5	LC1 K0610
ATV 31HU22M3X	2.2	3	GV2 L20	18	5	LC1 K0610
ATV 31HU30M3X	3	–	GV2 L22	25	5	LC1 D09
ATV 31HU40M3X	4	5	GV2 L22	25	5	LC1 D09
ATV 31HU55M3X	5.5	7.5	NS80HMA	50	22	LC1 D32
ATV 31HU75M3X	7.5	10	NS80HMA	50	22	LC1 D32
ATV 31HD11M3X	11	15	NS80HMA	80	22	LC1 D40
ATV 31HD15M3X	15	20	NS100HMA	100	22	LC1 D40
3-phase supply voltage: 380...500 V						
ATV 31H037N4	0.37	0.5	GV2 L07	2.5	5	LC1 K0610
ATV 31H055N4	0.55	0.75	GV2 L08	4	5	LC1 K0610
ATV 31H075N4	0.75	1	GV2 L08	4	5	LC1 K0610
ATV 31HU11N4	1.1	1.5	GV2 L10	6.3	5	LC1 K0610
ATV 31HU15N4	1.5	2	GV2 L14	10	5	LC1 K0610
ATV 31HU22N4	2.2	3	GV2 L14	10	5	LC1 K0610
ATV 31HU30N4	3	–	GV2 L16	14	5	LC1 K0610
ATV 31HU40N4	4	5	GV2 L16	14	5	LC1 K0610
ATV 31HU55N4	5.5	7.5	GV2 L22	25	22	LC1 D09
ATV 31HU75N4	7.5	10	GV2 L32	32	22	LC1 D18
ATV 31HD11N4	11	15	NS80HMA	50	22	LC1 D32
ATV 31HD15N4	15	20	NS80HMA	50	22	LC1 D32

(1) The HP values given are NEC-compliant (National Electrical Code).

(2) NS80HMA: product sold under the Merlin Gerin brand.

(3) Composition of contactors

LC1-K06: 3 poles + 1 "N/O" auxiliary contact

LC1-D09/D32/D40: 3 poles + 1 "N/O" auxiliary contact

(4) Usual control circuit voltages.

a.c. control circuit

	Volts ~	24	48	110	220	230	240
LC1-D	50 Hz	B5	E5	F5	M5	P5	U5
	60 Hz	B6	E6	F6	M6	–	U6
	50/60 Hz	B7	E7	F7	M7	P7	U7
	Volts ~	24	48	110	220/230	230	230/240
LC1-K	50/60 Hz	B7	E7	F7	M7	P7	U7

For other voltages between 24 and 660 V, or d.c. control circuit, please consult your Regional Sales Office.



Variable speed drives for asynchronous motors

Altivar 31 Motor starters

Applications

The combinations suggested below can be used to assemble a complete motor starter comprising a circuit-breaker, a contactor and an Altivar 31 variable speed drive.

The circuit-breaker provides protection against accidental short-circuits, isolation, and padlocking if required.

The contactor provides control and management of any safety features and isolation of the motor on stopping.

The Altivar 31 variable speed drive is electronically protected against short-circuits between phases and between phase and earth; it therefore provides continuity of service and thermal protection of the motor.

Motor starter for drive with heatsink

Variable speed drive Reference	Standard power rating of 4-pole 50/60 Hz motors (1)		Circuit-breaker (2)		Max. prosp. line Isc	Contactor (3) Add the voltage number to the basic reference to obtain the full reference (4)
	kW	HP	Reference	Rating		
3-phase supply voltage: 525...600 V						
ATV 31H075S6X	0.75	1	GV2 L08	4	5	LC1 K0610
ATV 31HU15S6X	1.5	2	GV2 L10	6.3	5	LC1 K0610
ATV 31HU22S6X	2.2	3	GV2 L14	10	5	LC1 K0610
ATV 31HU40S6X	4	5	GV2 L16	14	5	LC1 K0610
ATV 31HU55S6X	5.5	7.5	GV2 L20	18	22	LC1 K0610
ATV 31HU75S6X	7.5	10	GV2 L22	25	22	LC1 K0610
ATV 31HD11S6X	11	15	GV2 L32	32	22	LC1 D09
ATV 31HD15S6X	15	20	NS80HMA	32	22	LC1 D09

(1) The HP values given are NEC-compliant (National Electrical Code).

(2) NS80HMA: product sold under the Merlin Gerin brand.

(3) Composition of contactors

LC1-K06: 3 poles + 1 "N/O" auxiliary contact

LC1-D09/D32/D40: 3 poles + 1 "N/O" auxiliary contact

(4) Usual control circuit voltages.

a.c. control circuit

	Volts ~	24	48	110	220	230	240
LC1-D	50 Hz	B5	E5	F5	M5	P5	U5
	60 Hz	B6	E6	F6	M6	-	U6
	50/60 Hz	B7	E7	F7	M7	P7	U7
LC1-K	Volts ~	24	48	110	220/230	230	230/240
	50/60 Hz	B7	E7	F7	M7	P7	U7

For other voltages between 24 and 660 V, or d.c. control circuit, please consult your Regional Sales Office.



Variable speed drives for asynchronous motors

Altivar 31 Motor starters

Applications

The combinations suggested below can be used to assemble a complete motor starter comprising a circuit-breaker, a contactor and an Altivar 31 variable speed drive.

The circuit-breaker provides protection against accidental short-circuits, isolation, and padlocking if required.

The contactor provides control and management of any safety features and isolation of the motor on stopping.

The Altivar 31 variable speed drive is electronically protected against short-circuits between phases and between phase and earth; it therefore provides continuity of service and thermal protection of the motor.

Motor starter for customisable enclosed drive

Variable speed drive Reference	Standard power rating of 4-pole 50/60 Hz motors (1)		Circuit-breaker		Max. prosp. line Isc	Contactor Add the voltage number to the basic reference to obtain the full reference (2)
	kW	HP	Reference	Rating		
			A	kA		

Single phase supply voltage: 200...240 V

ATV 31C018M2	0.18	0.25	GV2 L08	4	1	LC1 K0610
ATV 31C037M2	0.37	0.5	GV2 L10	6.3	1	LC1 K0610
ATV 31C055M2	0.55	0.75	GV2 L14	10	1	LC1 K0610
ATV 31C075M2	0.75	1	GV2 L14	10	1	LC1 K0610
ATV 31CU11M2	1.1	1.5	GV2 L16	14	1	LC1 K0610
ATV 31CU15M2	1.5	2	GV2 L20	18	1	LC1 K0610
ATV 31CU22M2	2.2	3	GV2 L22	25	1	LC1 D09

3-phase supply voltage: 380...500 V

ATV 31C037N4	0.37	0.5	GV2 L07	2.5	5	LC1 K0610
ATV 31C055N4	0.55	0.75	GV2 L08	4	5	LC1 K0610
ATV 31C075N4	0.75	1	GV2 L08	4	5	LC1 K0610
ATV 31CU11N4	1.1	1.5	GV2 L10	6.3	5	LC1 K0610
ATV 31CU15N4	1.5	2	GV2 L14	10	5	LC1 K0610
ATV 31CU22N4	2.2	3	GV2 L14	10	5	LC1 K0610
ATV 31CU30N4	3	3	GV2 L16	14	5	LC1 K0610
ATV 31CU40N4	4	5	GV2 L16	14	5	LC1 K0610

(1) The HP values given are NEC-compliant (National Electrical Code).

(2) Usual control circuit voltages.

a.c. control circuit

	Volts ~	24	48	110	220	230	240
LC1-D	50 Hz	B5	E5	F5	M5	P5	U5
	60 Hz	B6	E6	F6	M6	-	U6
	50/60 Hz	B7	E7	F7	M7	P7	U7
	Volts ~	24	48	110	220/230	230	230/240
LC1-K	50/60 Hz	B7	E7	F7	M7	P7	U7

For other voltages between 24 and 660 V, or d.c. control circuit, please consult your Regional Sales Office.



GV2 L
+
LC1 K
+
ATV 31C●●●●●●

Variable speed drives for asynchronous motors

Altivar 31 Motor starters

Applications

The combinations suggested below can be used to assemble a complete motor starter comprising a circuit-breaker, a contactor and an Altivar 31 variable speed drive.

The circuit-breaker provides protection against accidental short-circuits, isolation, and padlocking if required.

The contactor provides control and management of any safety features and isolation of the motor on stopping.

The Altivar 31 variable speed drive is electronically protected against short-circuits between phases and between phase and earth; it therefore provides continuity of service and thermal protection of the motor.

Motor starter for drive kit

Variable speed drive Reference	Standard power rating of 4-pole 50/60 Hz motors (1)		Circuit-breaker		Max. prosp. line Isc	Contactor Add the voltage number to the basic reference to obtain the full reference (2)
	kW	HP	Reference	Rating		
			A	kA		

Single phase supply voltage: 200...240 V

ATV 31K018M2	0.18	0.25	GV2 L08	4	5	LC1 K0610
ATV 31K037M2	0.37	0.5	GV2 L10	6.3	5	LC1 K0610
ATV 31K055M2	0.55	0.75	GV2 L14	10	5	LC1 K0610
ATV 31K075M2	0.75	1	GV2 L14	10	5	LC1 K0610
ATV 31KU11M2	1.1	1.5	GV2 L14	14	22	LC1 K0610
ATV 31KU15M2	1.5	2	GV2 L20	18	22	LC1 K0610
ATV 31KU22M2	2.2	3	GV2 L22	25	22	LC1 D09

3-phase supply voltage: 380...500 V

ATV 31K037N4	0.37	0.5	GV2 L07	2.5	5	LC1 K0610
ATV 31K055N4	0.55	0.75	GV2 L08	4	5	LC1 K0610
ATV 31K075N4	0.75	1	GV2 L08	4	5	LC1 K0610
ATV 31KU11N4	1.1	1.5	GV2 L10	6.3	5	LC1 K0610
ATV 31KU15N4	1.5	2	GV2 L14	10	5	LC1 K0610
ATV 31KU22N4	2.2	3	GV2 L14	10	5	LC1 K0610
ATV 31KU30N4	3	3	GV2 L16	14	5	LC1 K0610
ATV 31KU40N4	4	5	GV2 L16	14	5	LC1 K0610
ATV 31KU55N4	5.5	7.5	GV2 L22	25	22	LC1 D09
ATV 31KU75N4	7.5	10	GV2 L32	32	22	LC1 D18
ATV 31KD11N4	11	15	NS80 HMA	50	22	LC1 D32
ATV 31KD15N4	15	20	NS80 HMA	50	22	LC1 D32

(1) The HP values given are NEC-compliant (National Electrical Code).

(2) Usual control circuit voltages.

a.c. control circuit

	Volts ~	24	48	110	220	230	240
LC1-D	50 Hz	B5	E5	F5	M5	P5	U5
	60 Hz	B6	E6	F6	M6	-	U6
	50/60 Hz	B7	E7	F7	M7	P7	U7
	Volts ~	24	48	110	220/230	230	230/240
LC1-K	50/60 Hz	B7	E7	F7	M7	P7	U7

For other voltages between 24 and 660 V, or d.c. control circuit, please consult your Regional Sales Office.



PowerSuite for PC welcome screen



PowerSuite for Pocket PC identification screen

Summary of functions

Drive factory setting	page 45
Functions of the display and keys	page 45
Remote display terminal option	page 46
Menu access levels	page 46
Menu access code	page 46
Operating speed range	page 46
Acceleration and deceleration ramp times	page 46
Acceleration and deceleration ramp profile	page 47
Ramp switching	page 47
Automatic adaptation of deceleration ramp	page 48
Voltage/frequency ratio	page 48
Auto-tuning	page 48
Switching frequency, noise reduction	page 48
Skip frequencies	page 49
Speed reference	page 49
Analog inputs	page 49
Preset speeds	page 49
+/- speed	page 50
Save reference	page 50
Step by step (JOG)	page 51
Control and reference channels	page 51
Reference switching	page 51
Summing inputs	page 51
PI regulator	page 52
Spooling	page 52
Current limit switching	page 53
Limiting low speed operating time	page 53
Motor switching	page 53
Control mode switching	page 53
2-wire control	page 54
3-wire control	page 54
Forced local mode	page 54
Freewheel stop	page 54
Fast stop	page 54
DC injection stop	page 54
Brake control	page 55
Management of limit switch	page 55
Monitoring	page 55
Fault management	page 56
Fault reset	page 56
General reset (resets all faults)	page 56
Controlled stop on loss of line supply	page 56
Stop mode in the event of a fault	page 56
Automatic catching a spinning load with speed detection	page 57
Automatic restart	page 57
Derated operation in the event of an overvoltage	page 57
Fault relay, unlocking	page 57
Operating time reset to zero	page 57
Motor thermal protection	page 58
Drive thermal protection	page 58
R1, R2 relay configuration	page 58
AOC/AOV analog outputs	page 59
Saving and retrieving the configuration	page 59
Function compatibility table	page 59

Variable speed drives for asynchronous motors

Altivar 31

Drive factory setting

The drive is supplied ready for use in most applications, with the following functions and settings:

- Nominal motor frequency: 50 Hz
- Motor voltage: 230 V (ATV 31H●●●M2 and M3X), 400 V (ATV 31H●●●N4) or 600 V (ATV 31H●●●S6X)
- Linear ramp times: 3 seconds
- Low speed (LSP): 0 Hz, high speed (HSP): 50 Hz
- Normal stop mode on deceleration ramp
- Stop mode in the event of a fault: Freewheel
- Motor thermal current = nominal drive current
- Standstill injection braking current = 0.7 x nominal drive current, for 0.5 seconds
- Constant torque operation, with sensorless flux vector control
- Logic inputs:
 - 2 directions of operation (LI1, LI2), 2-wire control
 - 4 preset speeds (LI3, LI4): LSP (low speed), 10 Hz, 15 Hz, 20 Hz
- Analog inputs:
 - AI1 speed reference (0 +10 V)
 - AI2 (0 ± 10 V) summing of AI1
 - AI3 (4-20 mA) not configured
- Relay R1: fault relay
- Relay R2: not assigned
- Analog output AOC: 0-20 mA, image of the motor frequency
- Automatic adaptation of the deceleration ramp in the event of excessive braking
- Switching frequency 4 kHz, random frequency

Functions of the display and keys

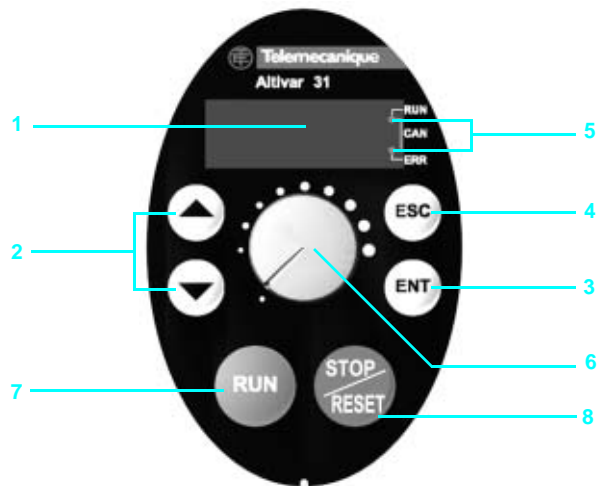

- 1 Information is displayed in the form of codes or values in four "7-segment" displays
 - 2 Buttons for scrolling through the menus or modifying values
 - 3 "ENT": Validation button for entering a menu or confirming the new value selected
 - 4 "ESC": Button for exiting the menu (no confirmation)
 - 5 2 diagnostic LEDs for the CANopen bus
- For ATV 31H●●●M2A, ATV 31H●●●M3XA and ATV 31H●●●N4A drives only:
 - 6 Speed reference potentiometer
 - 7 "RUN": Local control of motor operation
 - 8 STOP/RESET: Controls motor stopping locally and resets any faults

Variable speed drives for asynchronous motors

Altivar 31

563220



Remote display terminal

Remote display terminal option

The remote display terminal can be mounted on the door of a wall-fixing or floor-standing enclosure.

It comprises an LCD display with programming and control keys and a switch for locking access to the menus.

Drive control keys

- "FWD/RV": reversal of the direction of rotation
- "RUN": motor run command
- "STOP/RESET": motor stop command or fault reset

The speed reference is given by the remote display terminal. Only the freewheel, fast stop and DC injection stop commands remain active on the terminal block. If the drive/operator terminal link is broken, the drive locks in fault mode.

Its subsequent action depends on the control and reference channel programming.

Note: Protection via customer confidential code has priority over the switch.

Menu access levels

There are 3 access levels:

Level 1: Access to standard functions. Significantly, this level is interchangeable with the Altivar 28.

Level 2: Access to advanced application functions.

Level 3: Access to advanced application functions and management of mixed control modes.

Menu access code

Enables the drive configuration to be protected using an access code.

When access is locked using a code, only the adjustment and monitoring parameters can be accessed.

Operating speed range

Used to determine the 2 frequency limits which define the speed range permitted by the machine under actual operating conditions for all applications with or without overspeed.

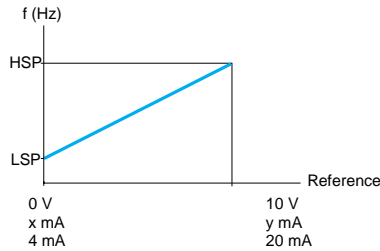

LSP: low speed, from 0 to HSP, factory setting 0
 HSP: high speed, from LSP to f max., factory setting 50 Hz
 x: configurable between 0 and 20 mA, factory setting 4 mA
 y: configurable between 4 and 20 mA, factory setting 20 mA

563714

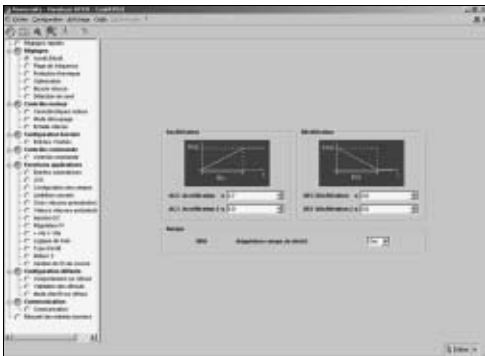

Ramp adjustment with PowerSuite for PC

Acceleration and deceleration ramp times

Used to define acceleration and deceleration ramp times according to the application and the machine dynamics.

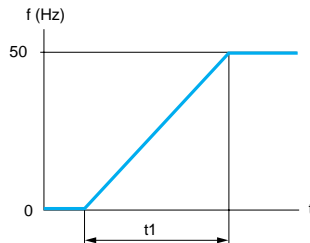

Linear acceleration ramp

t1: acceleration time
 t2: deceleration time

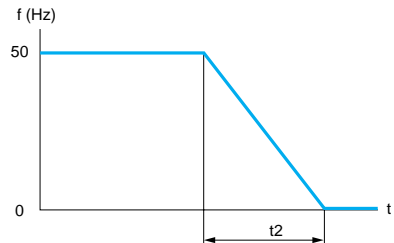

Linear deceleration ramp

t1 and t2 can be set independently between 0.1 and 999.9 s, factory setting: 3 s

Variable speed drives for asynchronous motors

Altivar 31

Acceleration and deceleration ramp profile

Used to gradually increase the output frequency starting from a speed reference, following a linear ratio or a preset ratio.

- For applications such as material handling, packaging, transportation of people: the use of S ramps takes up mechanical play and eliminates jolts, and limits "non-following" of speed during rapid transient operation of high inertia machines.
- For pumping applications (installation with centrifugal pump and non-return valve): valve closing can be controlled more accurately if U ramps are used.
- Selecting "linear", "S", "U" or customized profiles will affect both the acceleration and deceleration ramps.

S ramps

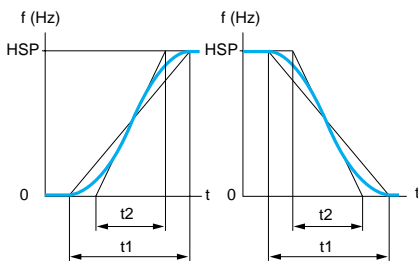

HSP: high speed
t1: ramp time set
t2 = 0.6 x t1
The curve coefficient is fixed.

U ramps

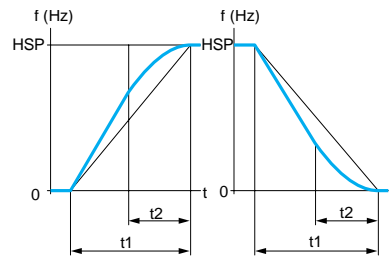

HSP: high speed
t1: ramp time set
t2 = 0.5 x t1
The curve coefficient is fixed.

Customized ramps

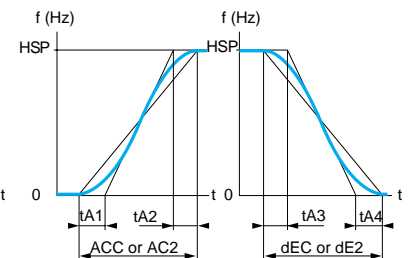

HSP: high speed
tA1: can be set between 0 and 100% (of ACC or AC2)
tA2: can be set between 0 and (100% - tA1) (of ACC or AC2)
tA3: can be set between 0 and 100% (of dEC or dE2)
tA4: can be set between 0 and (100% - tA3) (of dEC or dE2)
ACC: acceleration ramp 1 time
AC2: acceleration ramp 2 time
dEC: deceleration ramp 1 time
dE2: deceleration ramp 2 time

Ramp switching

Used to switch 2 acceleration or deceleration ramp times, which can be adjusted separately.

Ramp switching can be enabled by:

- a logic input
- a frequency threshold
- a combination of logic input and frequency threshold

Function suitable for:

- material handling with smooth starting and approach
- machines with fast steady state speed correction

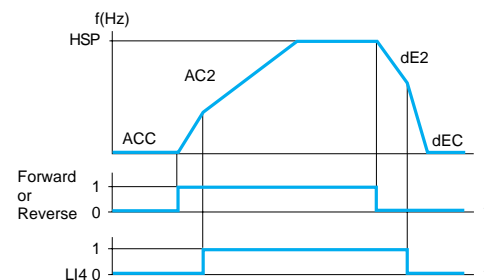

Acceleration 1 (ACC) and deceleration 1 (dEC):
- adjustment 0.1 to 999.9 s
- factory setting 3 s
Acceleration 2 (AC2) and deceleration 2 (dE2):
- adjustment 0.1 to 999.9 s
- factory setting 5 s
HSP: high speed

Example of switching using logic input LI4

Variable speed drives for asynchronous motors

Altivar 31

663715

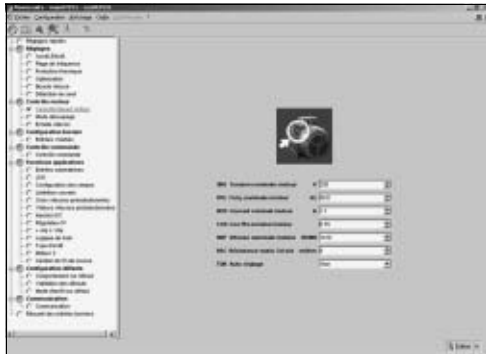

Adjustment of the voltage/frequency ratio with PowerSuite for PC

■ Automatic adaptation of deceleration ramp

Used to automatically adapt the deceleration ramp if the initial setting is too low when the load inertia is taken into account. This function avoids the drive locking in the event of an **excessive braking** fault.

Function suitable for all applications not requiring precise stopping and not using braking resistors.

Automatic adaptation must be cancelled if the machine has position control with stopping on a ramp and a braking resistor installed. This function is automatically disabled if the brake sequence is configured.

■ Voltage/frequency ratio

- Motor and power supply characteristics

Used to determine the limit values for the voltage/frequency ratio according to the line supply, the motor and the application.

The following values should be set for variable or constant torque applications with or without overspeed:

- the base frequency corresponding to the supply
- the nominal motor frequency (in Hz) given on the motor rating plate
- the nominal motor voltage (in V) given on the motor rating plate
- the maximum output frequency of the drive (in Hz)

- Type of voltage/frequency ratio

Used to adapt the voltage/frequency ratio to the application in order to optimize performance for the following applications:

- Constant torque applications (machines with average loads operating at low speed) with motors connected in parallel or special motors (e.g.: resistive cage motor): ratio **L**

- Variable torque applications (pumps, fans): ratio **P**

- Machines with heavy loads operating at low speed, machines with fast cycles, with (sensorless) flux vector control: ratio **n**

- Energy saving, for machines with slow speed and torque variations: ratio **nLd**

Voltage is automatically reduced to a minimum according to the necessary torque

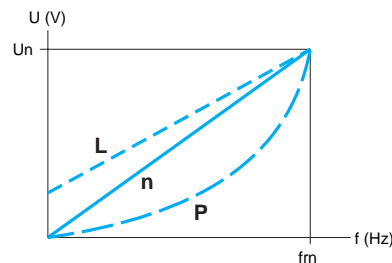

Un: Nominal motor voltage
fm: Nominal motor frequency

■ Auto-tuning

Auto-tuning may be performed:

- voluntarily by the operator using dialogue tools via local control mode or the serial link
- each time the drive is switched on
- on each run command
- by enabling a logic input

Auto-tuning is used to optimize application performance.

■ Switching frequency, noise reduction

The switching frequency can be adjusted to reduce the noise generated by the motor.

The switching frequency is modulated randomly in order to avoid resonance. This function can be disabled if it causes instability.

High frequency switching of the intermediate DC voltage can be used to supply the motor with a current wave that has a lower harmonic distortion. The switching frequency can be adjusted during operation to reduce the noise generated by the motor.

Value: 2 to 16 kHz, with a factory setting of 4 kHz.

For all applications which require low motor noise.

Variable speed drives for asynchronous motors

Altivar 31

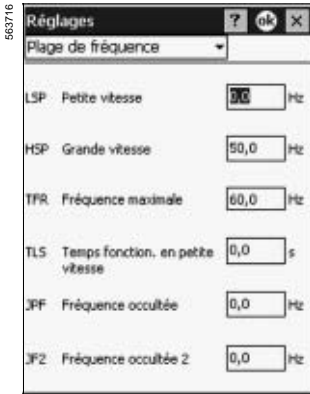

Adjustment of the skip frequency with PowerSuite for Pocket PC

■ Skip frequencies

Used to suppress one or two critical speeds which may be the cause of mechanical resonance.

It is possible to prohibit the prolonged operation of the motor on 1 or 2 frequency bands (with a bandwidth of ± 1 Hz), which can be set within the operating range. Function suitable for lightweight machines, bulk product conveyors with unbalanced motor, fans and centrifugal pumps.

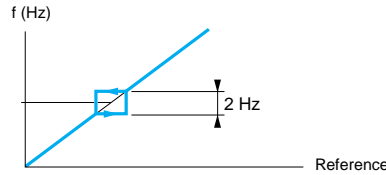

Motor speed change depending on the skip frequency reference

■ Speed reference

The speed reference can have different sources depending on the drive configuration:

- references provided by 3 analog inputs
- the potentiometer reference (for ATV 31●●●A drives only)
- the +/- speed function via logic input, using the keypad or remote terminal keys
- the remote display terminal reference
- speed references provided by the communication bus or networks

These different sources are managed by programming the reference functions and channels.

■ Analog inputs

There are 3 analog inputs:

- 2 voltage inputs:
 - 0-10 V (AI1)
 - ± 10 V (AI2)
- 1 current input:
 - X-Y mA (AI3) where X is configurable between 0 and 20 mA, and Y is configurable between 4 and 20 mA.

■ Preset speeds

Used to switch preset speed references.

2, 4, 8 or 16 preset speeds can be selected.

Enabled by means of 1, 2, 3 or 4 logic inputs.

The preset speeds can be adjusted in increments of 0.1 Hz from 0 Hz to 500 Hz.

Function suitable for material handling and machines with several operating speeds.

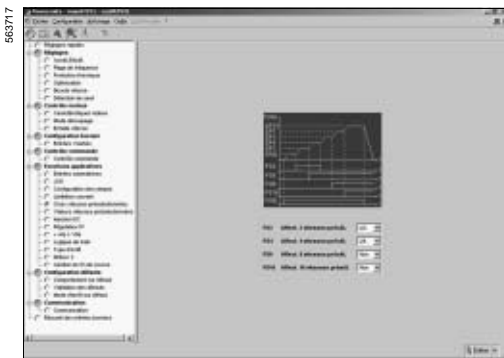

Adjustment of preset speeds with PowerSuite for PC

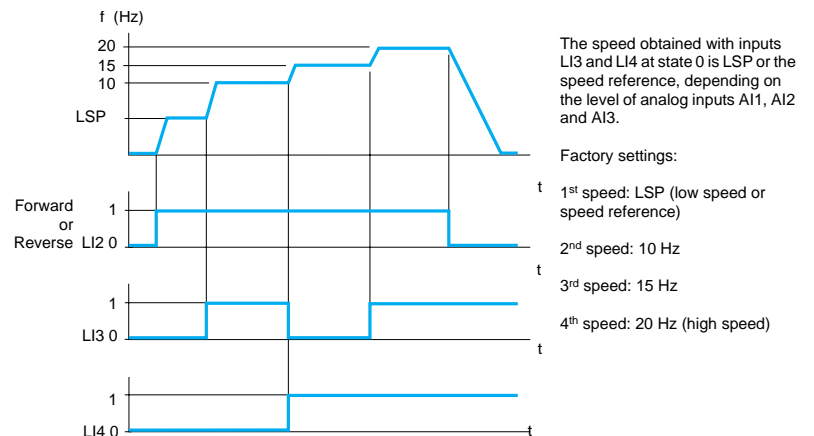

Example of operation with 4 preset speeds and 2 logic inputs

Variable speed drives for asynchronous motors

Altivar 31

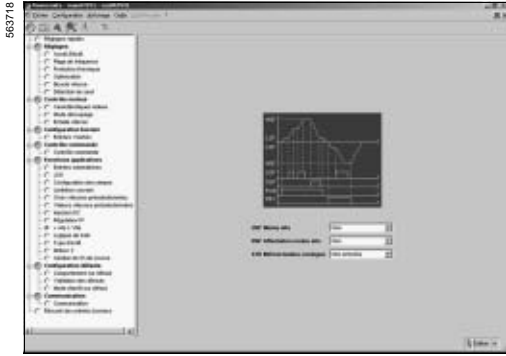

Adjustment of the +/- speed function with PowerSuite for PC

■ +/- speed

Used to increase or decrease a speed reference by means of 1 or 2 logic inputs, with or without the last reference being saved (motorised potentiometer function). This function is suitable for centralised control of a machine with several sections operating in one direction or for control by a pendant control station of a handling crane with two operating directions.

Two types of operation are available:

- Use of single action buttons: Two logic inputs are required in addition to the operating direction(s). The input assigned to the "+ speed" command increases the speed, the input assigned to the "- speed" command decreases the speed.

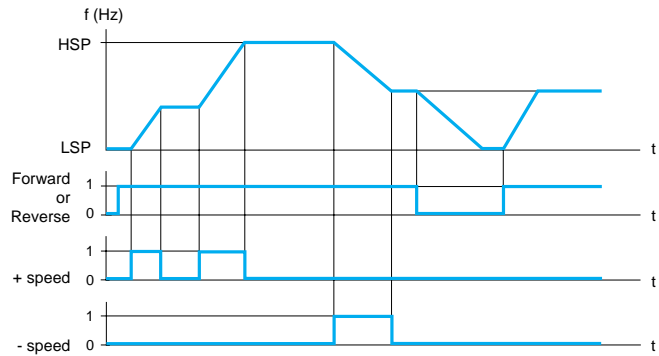

Example of "+/- speed" with 2 logic inputs, single action buttons and reference saving

- Use of double action buttons (only one logic input assigned to "+ speed" is necessary):

Logic inputs:

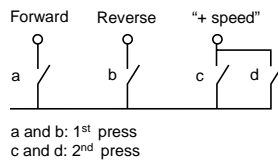

	Released (- speed)	1 st press (speed maintained)	2 nd press (+ speed)
Forward button	-	a	a and b
Reverse button	-	c	c and d

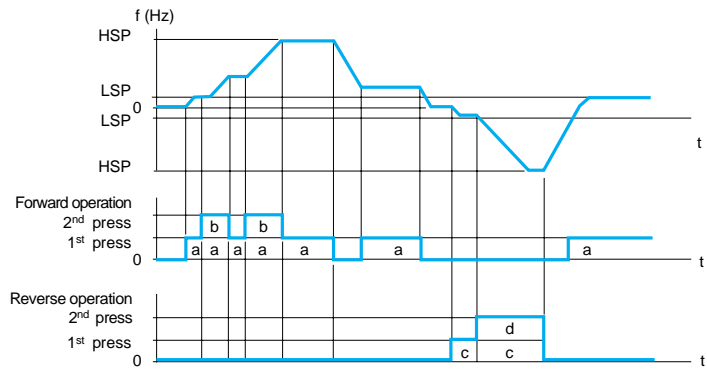

LSP: low speed, HSP: high speed
Example with double action buttons and 1 logic input

Note: This type of "+/- speed" control is incompatible with 3-wire control

■ Save reference

This function is associated with "+/- speed" control. Enables the reading and saving of the last speed reference prior to the loss of the run signal or mains supply. The saved reference is applied at the next run signal.

Variable speed drives for asynchronous motors

Altivar 31

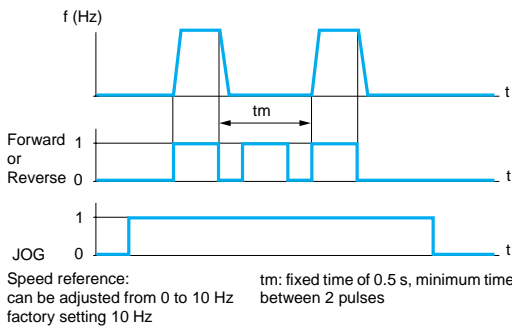

Example of jog operation

■ Step by step (JOG)

Used for pulse operation with minimum ramp times (0.1 s), limited speed reference and minimum time between 2 pulses.
Enabled by a logic input and pulses given by the operating direction command.

This function is suitable for machines with product insertion in manual mode (example: gradual movement of the mechanism during maintenance operations).

■ Control and reference channels

There are several control and reference channels which can be independent. Commands (forward, reverse, etc.) and speed references can be sent using the following methods:

- terminals (logic and analog inputs)
- keypad for ATV 31●●●A only (RUN/STOP and potentiometer)
- ATV 31 keypad
- via the serial link
 - remote display terminal
 - Modbus control word
 - CANopen control word

The control and speed reference channels can be separate.

Example: speed reference issued by CANopen and commands issued by the remote display terminal.

Note: The STOP keys on the keypad and the remote display terminal may retain priority. The "summing inputs" and "PI regulator" functions only apply to one reference channel.

■ Reference switching

Switching between 2 speed references can be enabled via:

- a logic input
 - a bit in a Modbus or CANopen control word
- Reference 1 is active if the logic input (or control word bit) is at 0, reference 2 is active if the logic input (or control word bit) is at 1.

The reference can be switched with the motor running.

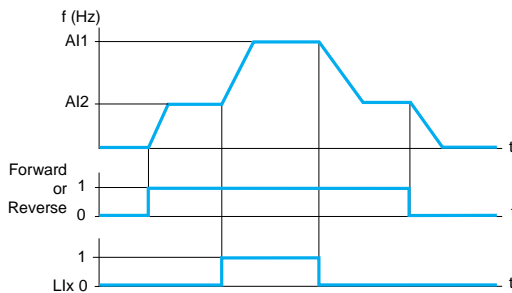

Example of reference switching

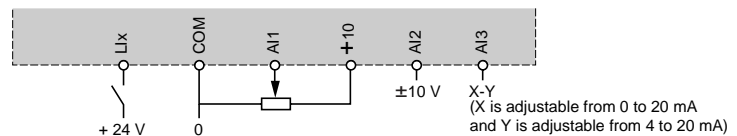

Connection diagram for reference switching

■ Summing inputs

Used to add up 2 or 3 speed references from different sources.

The references to be added together are selected from all the possible types of speed reference.

Example:

Reference 1 sent by AI1

Reference 2 sent by AI2

Reference 3 sent by AI3

Drive speed reference: reference 1 + reference 2 + reference 3.

Variable speed drives for asynchronous motors

Altivar 31

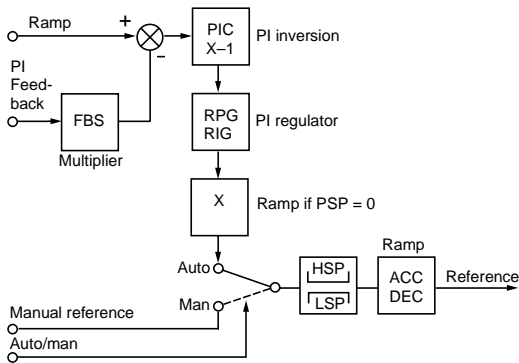

ACC: Acceleration
 DEC: Deceleration
 FBS: PI feedback multiplication coefficient
 HSP: High speed
 PIC: Reversal of the direction of correction of the PI regulator
 LSP: Low speed
 RIG: PI regulator integral gain
 RPG: PI regulator proportional gain

PI regulator

PI regulator

Used for simple control of a flow rate or a pressure with a sensor which supplies a feedback signal adapted to the drive. This function is suitable for pumping and ventilation applications.

PI reference:

- internal regulator reference, adjustable from 0 to 100
- regulation reference selected from all the possible types of regulation reference
- preset PI references

2 or 4 preset PI references, adjustable from 0 to 100, require the use of 1 or 2 logic inputs respectively

Manual reference

- speed reference selected from all the possible types of speed reference

PI feedback:

- analog input AI1, AI2 or AI3

Auto/Man:

- logic input LI for switching operation to speed reference (Man) or PI regulation (Auto).

During operation in automatic mode it is possible to adapt the process feedback, to correct inverse PI, to adjust the proportional and integral gain and to apply a ramp (time = ACC - DEC) for establishing the PI action on starting and stopping. The motor speed is limited to between LSP and HSP.

Note: The PI function is incompatible with the "preset speeds" and "step by step (JOG)" functions. The PI reference can also be transmitted on line via the Modbus RS 485 serial link or via the CANopen bus.

Spooling (Function only available with ATV 31...T drives)

Function for winding reels of thread (in textile applications)

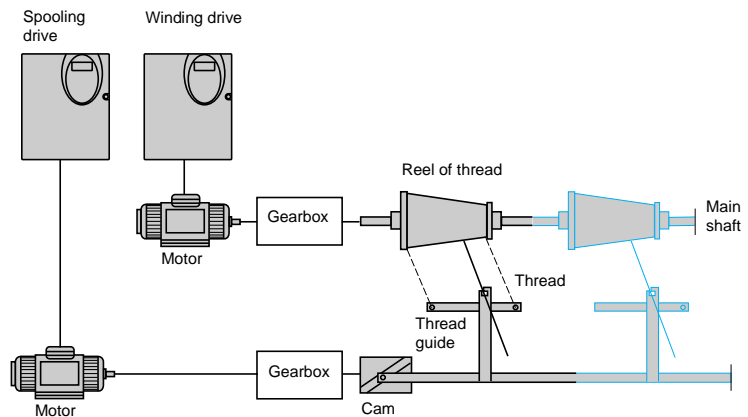

The cam speed of rotation must follow a precise profile to ensure steady winding.

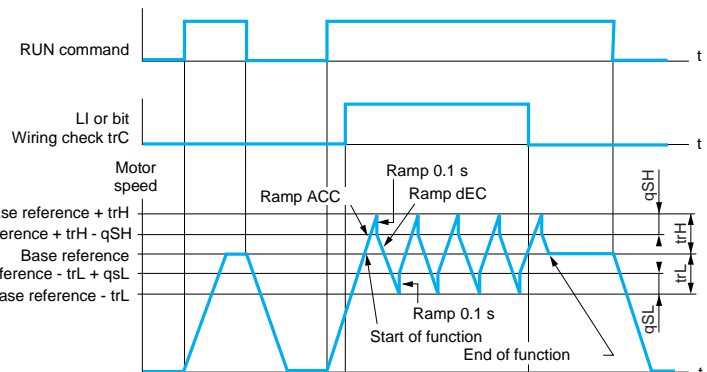

When the function is configured, the ramp type is forced to linear ramp.

Variable speed drives for asynchronous motors

Altivar 31

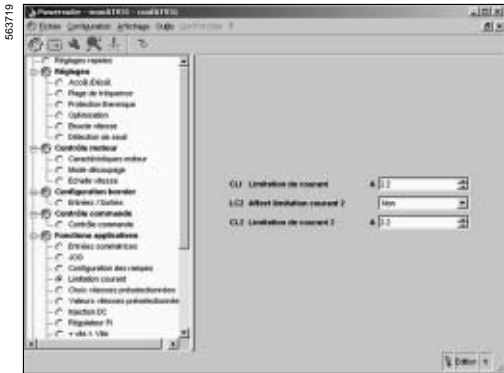

Configuration of current switching with PowerSuite for PC

■ Current limit switching

A 2nd current limit can be configured between 0.25 and 1.5 times the nominal drive current.

Used to limit the torque and the temperature rise of the motor.

Switching between 2 current limits can be enabled via:

- a logic input
- a bit in a Modbus or CANopen control word

■ Limiting low speed operating time

The motor is stopped automatically after an operating period at low speed (LSP) with zero reference and run command present.

This time can be set between 0.1 and 999.9 seconds

(0 corresponds to an unlimited time).

Factory setting 0 s. The motor restarts automatically on the ramp when the reference reappears or if the run command is broken and then re-established.

This function is suitable for automatic stopping/starting on pressure-regulated pumps.

■ Motor switching

Allows two motors with different powers to be supplied successively by the same drive. Switching must take place with the drive stopped and locked, using an appropriate sequence at the drive output.

The function can be used to adapt the motor parameters. The following parameters are switched automatically:

- nominal motor voltage
- nominal motor frequency
- nominal motor current
- nominal motor speed
- motor cosine Phi
- selection of the type of voltage/frequency ratio for motor 2
- IR compensation, motor 2
- motor frequency loop gain
- motor stability
- motor slip compensation

Motor thermal protection is disabled by this function.

Motor switching can be enabled by:

- a logic input
- a bit in a Modbus or CANopen control word

With hoisting applications, this function enables a single drive to be used for vertical and horizontal movements.

■ Control mode switching

Control channel switching provides a choice of 2 operating modes.

Switching can be enabled by:

- a logic input
- a bit in a Modbus or CANopen control word

Variable speed drives for asynchronous motors

Altivar 31

2-wire control

Used to control the direction of operation by means of a maintained contact. Enabled by means of 1 or 2 logic inputs (one or two directions).

This function is suitable for all non-reversing and reversing applications.

3 operating modes are possible:

- detection of the state of the logic inputs
- detection of a change in state of the logic inputs
- detection of the state of the logic inputs with forward operation always having priority over reverse

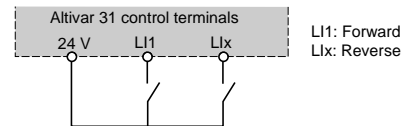

Wiring diagram for 2-wire control

3-wire control

Used to control the operating direction and stopping by means of pulsed contacts. Enabled by means of 2 or 3 logic inputs (non-reversing or reversing).

This function is suitable for all non-reversing and reversing applications.

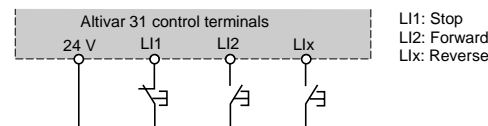

Wiring diagram for 3-wire control

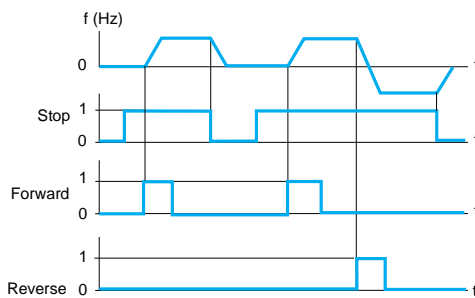

Example of operation with 3-wire control

Forced local mode

Forced local mode imposes control via the terminals or operator terminal and prohibits all other control modes.

The following references and commands are available for forced local mode:

- references AI1, or AI2, or AI3 and control via logic inputs
 - reference and control via RUN/STOP keys and potentiometer (ATV 31●●●A drives only)
 - reference and control via the remote display terminal
- The changeover to forced local mode is enabled by a logic input.

Freewheel stop

Stops the motor by resistive torque only if the motor power supply is cut.

A freewheel stop is achieved:

- by configuring a normal stop command as a freewheel stop (on disappearance of a run command or appearance of a stop command)
- by enabling a logic input

Fast stop

Used to achieve a braked stop with an acceptable deceleration ramp time (divided by 2 to 10) for the drive/motor unit to avoid locking on an excessive braking fault. Used for conveyors with emergency stop electrical braking.

A fast stop is achieved:

- by configuring a normal stop as a fast stop (on disappearance of a run command or appearance of a stop command)
- by enabling a logic input

DC injection stop

Used to brake (at low speed) high inertia fans, or to maintain torque on stopping in the case of fans located in an airflow.

A DC injection stop is achieved:

- by configuring a normal stop as a DC injection stop (on disappearance of a run command or appearance of a stop command)
- by enabling a logic input

The DC value and the standstill braking time are adjustable.

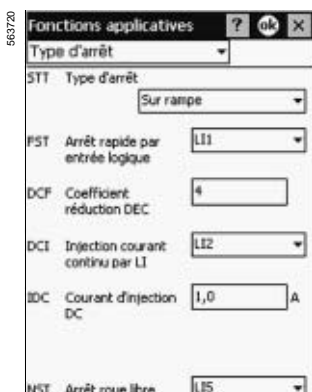

Configuration of stop types with PowerSuite for Pocket PC

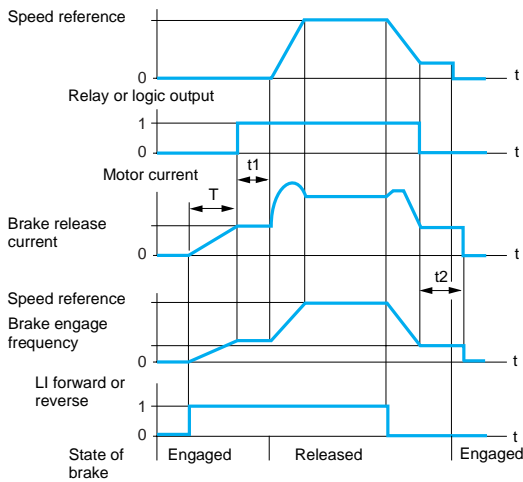

Accessible settings:
t1: Brake release time delay
t2: Brake engage time delay

Brake control

■ Brake control

Used to manage control of an electromagnetic brake in synchronization with the starting and stopping of the motor to avoid jolts and load veering.

The brake control sequence is managed by the drive.

Values that can be adjusted for releasing the brake: current threshold and time delay
Values that can be adjusted for engaging the brake: frequency threshold and time delay

Enabled: by relay logic output R2 or logic output AOC assigned to brake control.

Function suitable for material handling applications with movements equipped with electromagnetic brakes (hoisting) and machines requiring a parking brake (unbalanced machines).

□ Principle:

- Vertical lifting movement:

Maintain motor torque in an upward direction when the brake is being released and engaged, in order to hold the load, and start smoothly as soon as the brake is released.

- Horizontal lifting movement:

Synchronizes brake release with the build-up torque on starting and brake engage at zero speed on stopping, in order to prevent jerking.

Recommended settings for brake control for a vertical lifting application (for a horizontal lifting application set the current threshold to zero):

- Brake release current: Adjust the brake release current to the nominal current indicated on the motor. If, during testing, the torque is insufficient, increase the brake release current (the maximum value is imposed by the drive).

- Acceleration time: For lifting applications it is advisable to set the acceleration ramps to more than 0.5 seconds. Ensure that the drive does not change to current limiting.

The same recommendation applies for deceleration.

Note: For a lifting movement, a braking resistor should be used. Ensure that the settings and configurations selected cannot cause a drop or a loss of control of the lifted load.

- Brake release time delay t1: Adjust according to the type of brake. It is the time required for the mechanical brake to release.

- Brake engage frequency: Set to twice the nominal slip then adjust according to the result.

- Brake engage time delay t2: Adjust according to the type of brake. It is the time required for the mechanical brake to engage.

■ Management of limit switch

Used to manage the operation of one or two limit switches (with 1 or 2 operating directions).

Each limit (forward, reverse) is associated with a logic input. The type of stop that occurs on detection of a limit can be configured as normal, freewheel or fast.

Following a stop, the motor is permitted to restart in the opposite direction only.

■ Monitoring

The following data can be displayed:

- frequency reference
- internal PI reference
- frequency reference (absolute value)
- output frequency applied to the motor (value signed in two's complement)
- output value in customer units
- current in the motor
- motor power: 100% = nominal power
- line voltage
- motor thermal state:
100%: nominal thermal state, 118%: motor overload threshold
- drive thermal state:
100%: nominal thermal state, 118%: drive overload threshold
- motor torque: 100% = nominal torque
- last fault
- operating time
- auto-tuning status
- configuration and state of logic inputs
- configuration of analog inputs



Monitoring the different parameters with PowerSuite for PC



Monitoring the different parameters with the oscilloscope function in PowerSuite for PC

Variable speed drives for asynchronous motors Altivar 31

563723



Fault management with PowerSuite for PC

■ Fault management

There are different modes of operation on a resettable fault:

- Freewheel stop
- The drive switches to the fallback speed
- The drive maintains the speed at which it was operating when the fault occurred until the fault disappears
- Stop on ramp
- Fast stop

The detected resettable faults are as follows:

- drive overheating
- motor overheating
- CANopen bus fault
- Modbus serial link failure
- external faults
- loss of 4-20 mA signal

■ Fault reset

Used to clear the last fault by means of a logic input.

The restart conditions after a reset to zero are the same as those of a normal power-up.

Resets the following faults: overvoltage, overspeed, external fault, drive overheating, motor phase loss, DC bus overvoltage, loss of 4-20 mA reference, load veering, motor overload if the thermal state is less than 100%, serial link fault.

"Line supply undervoltage" and "line supply phase loss" faults are reset automatically when the line supply is restored.

Function suitable for applications where the drives are difficult to access, for example on moving parts in material handling systems.

■ General reset (resets all faults)

This function can be used to inhibit all faults, including thermal protection (forced operation) and may cause irreparable damage to the drive.

Function suitable for applications where a restart can be vital (conveyor in a furnace, smoke extraction station, machine with hardening products which need to be removed).

The function is enabled by a logic input.

Fault monitoring is active if the logic input is at state 1.

All faults are reset on a change of state \uparrow of the logic input.

■ Controlled stop on loss of line supply

Used to control motor stopping on a loss of line supply.

Function suitable for material handling, machines with high inertia, continuous product processing machines.

Type of stop possible:

- locking of the drive and freewheel stop
- stop which uses the mechanical inertia to maintain the drive power supply as long as possible
- stop on ramp
- fast stop (depends on the inertia and the braking ability of the drive)

■ Stop mode in the event of a fault

The type of stop that occurs on detection of a fault can be configured as normal, freewheel or fast for the following faults:

- external fault (detection enabled by a logic input or a bit in a Modbus or CANopen control word)
- motor phase loss fault

If a downstream contactor is being used between the drive and the motor, the motor phase loss fault should be inhibited.

Variable speed drives for asynchronous motors

Altivar 31

■ Automatic catching a spinning load with speed detection ("catch on the fly")

Used to restart the motor smoothly after one of the following events, provided the run command is still present:

- loss of line supply or simple switch off
- fault reset or automatic restart
- freewheel stop

On disappearance of the event, the effective speed of the motor is detected in order to restart on a ramp at this speed and return to the reference speed. The speed detection time can be up to 1 s depending on the initial deviation.

This function is automatically disabled if the brake sequence is configured.

This function is suitable for machines where the speed loss is negligible during the time over which the mains supply is lost (machines with high inertia), fans and pumps driven by residual flow, etc.

■ Automatic restart

Enables the drive to be restarted automatically after locking following a fault if this fault has disappeared and if the other operating conditions permit a restart.

This restart is performed by a series of automatic attempts separated by increasingly longer wait periods of 1 s, 5 s, 10 s then 1 minute for the rest.

The whole restart procedure can last anywhere from 5 minutes to an unlimited time. If the drive has not restarted after the configured time, it will lock and the procedure is abandoned until it has been switched off and on again.

The faults permitting this restart are:

- line supply overvoltage
- motor thermal overload
- drive thermal overload
- DC bus overvoltage
- failure of a line supply phase
- external fault
- loss of 4-20 mA reference
- CANopen bus fault
- Modbus serial link fault
- line supply voltage too low. For this fault, the function is always active, even if it is not configured.

For these types of fault, the relay configured as a fault relay remains activated if the function is configured. The speed reference and the direction of operation must be maintained for this function.

This function is suitable for machines or installations in continuous operation or without monitoring, and where a restart will not endanger equipment or personnel in any way.

■ Derated operation in the event of an overvoltage

The line voltage monitoring threshold is lowered to 50% of the motor voltage.

In this case, a line choke must be used and the performance of the drive cannot be guaranteed.

■ Fault relay, unlocking

The fault relay is energised when the drive is powered up and is not faulty.

It contains a "C/O" common point contact.

The drive can be unlocked after a fault in one of the following ways:

- by powering down until the "ON" LED extinguishes, then switching the power back on
- by assigning a logic input to the "reset faults" function
- by the "automatic restart" function, if it has been configured

■ Operating time reset to zero

The drive operating time can be reset to zero.



Configuration of the fault relay with PowerSuite for Pocket PC

Variable speed drives for asynchronous motors

Altivar 31

■ Motor thermal protection

Indirect motor thermal protection is implemented via continuous calculation of its theoretical temperature rise. Thermal protection can be adjusted from 0.2 to 1.5 times the nominal drive current. This function is suitable for applications with self-cooled motors.

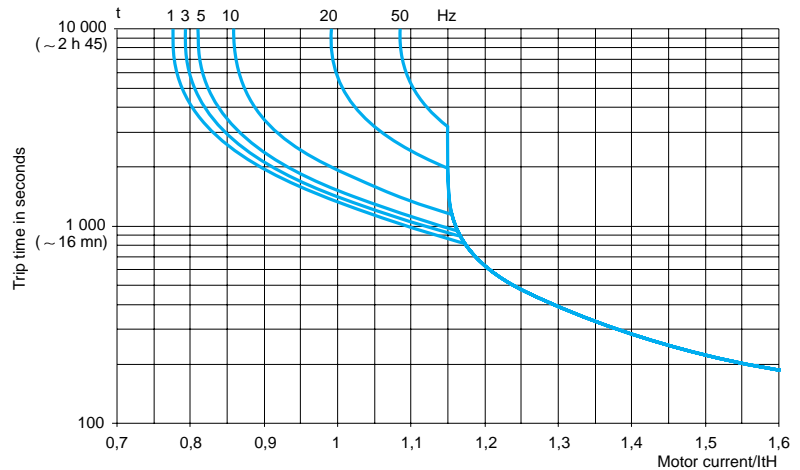

Motor thermal protection curves

■ Drive thermal protection

Thermal protection, by a PTC probe fitted on the heatsink or integrated in the power module, ensures that the drive is protected in the event of poor ventilation or excessive ambient temperatures. Locks the drive in the event of a fault.

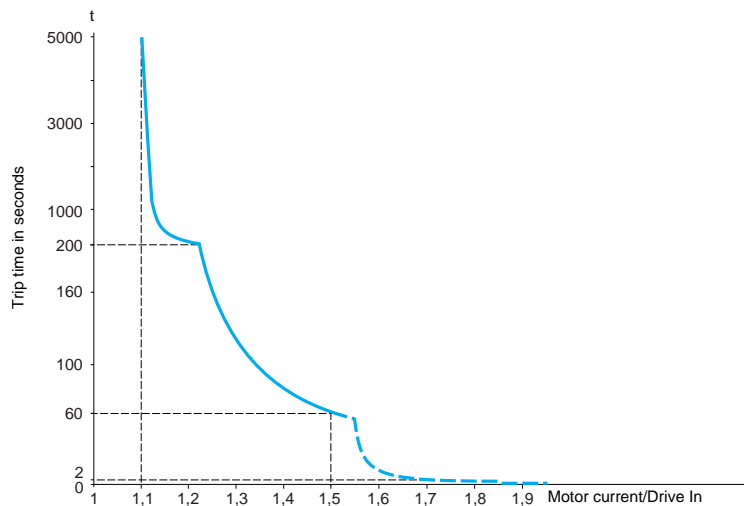

■ R1/R2 relay configuration

The following states are signalled when the relay is powered on:

- drive fault
- drive running
- frequency threshold reached
- high speed reached
- current threshold reached
- frequency reference reached
- motor thermal threshold reached
- brake sequence (R2 only)

Variable speed drives for asynchronous motors

Altivar 31

563725



Configuration of AOC/AOV outputs with PowerSuite for PC

■ AOC/AOV analog output

The same data is available on analog outputs AOC and AOV. The following assignments are possible:

- motor current
- motor frequency
- motor torque
- power supplied by the drive
- drive fault
- frequency threshold reached
- high speed reached
- current threshold reached
- frequency reference reached
- motor thermal threshold reached
- brake sequence

The adjustment of analog output AOC/AOV is used to modify the characteristics of the current analog output AOC or the voltage analog output AOV.

AOC: can be set as 0-20 mA or 4-20 mA

AOV: can be set at 0-10 V

■ Saving and retrieving the configuration

A configuration can be saved to the EEPROM. This function is used to store a configuration in addition to the current configuration.

Retrieving this configuration clears the current configuration.

Function compatibility table

■ Configurable I/O

Functions which are not listed in this table are fully compatible.

Stop functions have priority over run commands.

The selection of functions is limited:

- by the number of drive I/O

- by the incompatibility of certain functions with one another

Functions	Summing inputs	+/- speed	Management of limit switch	Preset speeds	PI regulator	Jog operation	Brake sequence	DC injection stop	Fast stop	Freewheel stop
Summing inputs		⊖		↑	⊖	↑				
+/- speed	⊖			⊖	⊖	⊖				
Management of limit switch					⊖					
Preset speeds	←	⊖			⊖	↑				
PI regulator	⊖	⊖	⊖	⊖		⊖	⊖			
Jog operation	←	⊖		←	⊖		⊖			
Brake sequence					⊖	⊖		⊖		
DC injection stop							⊖			↑
Fast stop										↑
Freewheel stop							←	←		

- Incompatible functions
- Compatible functions
- Not applicable

Priority functions (functions which cannot be active at the same time)

- The arrow indicates which function has priority
- Example: the "Freewheel stop" function has priority over the "Fast stop" function