

Ring Main Unit

RM6 Merlin Gerin 24 kV

Catalog
2003

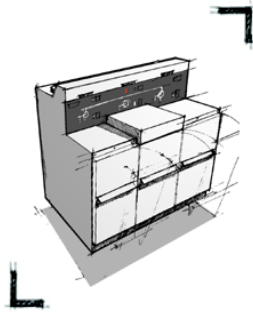

Merlin Gerin

Schneider
 **Electric**
Building a New Electric World

Field of application	2
Experience of a world leader	4
Innovations	5
Telecontrol of power distribution networks	6
Main characteristics	8
Description of the range	10
Description of the switchgear	12
Protection of transformers	14
Protection of a feeder cable	16
Choice of connection	18
Accessories	23
Dimensions and installation	26
Civil engineering	28
A leader's references	29
Quality assurance	30
Preserving the environment	31
Order form	32

Field of application

The RM6 can be adapted to meet all medium voltage power distribution needs, up to 24 kV.

The RM6 is a compact unit combining all MV functional units to enable connection, supply and protection of one or two transformers on an open ring or radial network

- by a fuse-switch combination, up to 2000 kVA
 - by a circuit breaker with self-powered protection unit, up to 3000 kVA
- The switchgear and busbars are enclosed in a gas-tight chamber, filled with SF6 and sealed for life.

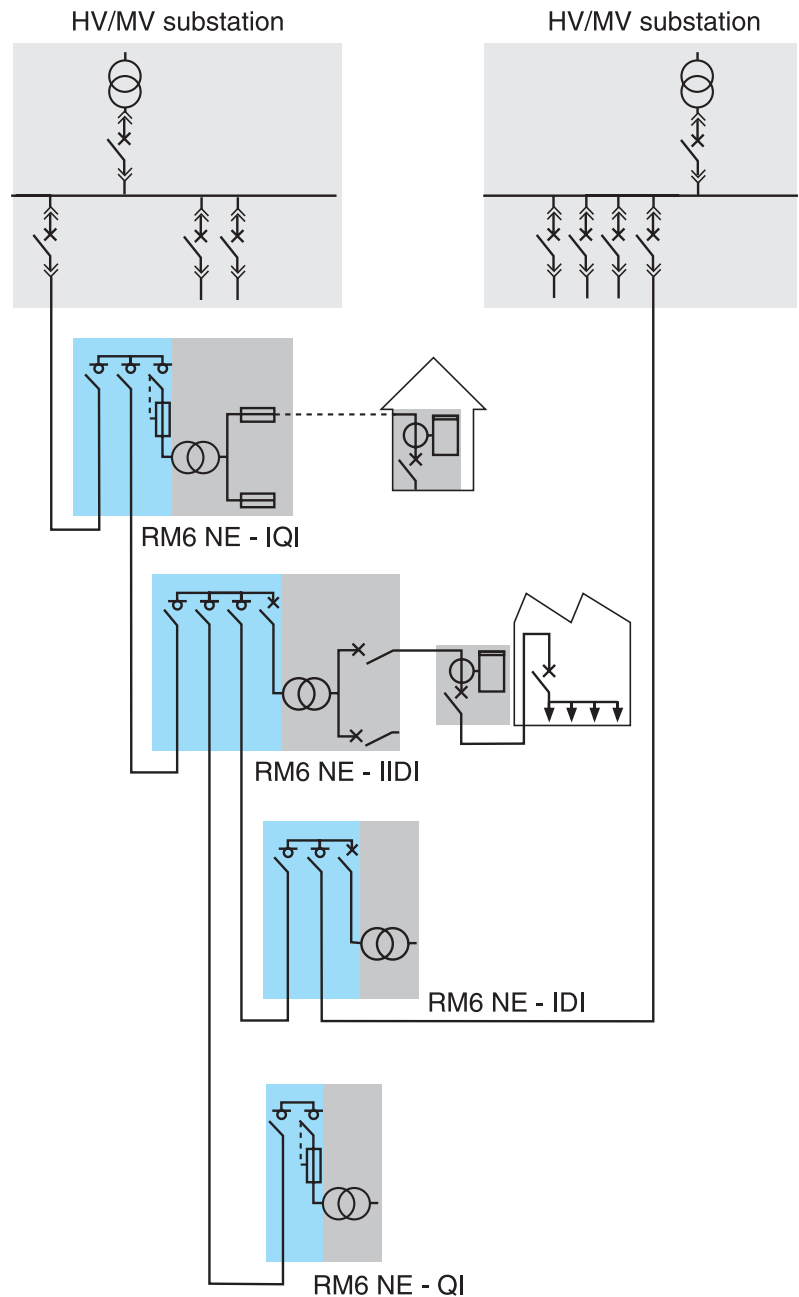

A complete range, enabling you to equip MV network points, and enhance electrical power dependability.

Operating a distribution network sometimes requires switching points in addition to the HV/MV substations, in order to limit the effect of a fault on the network.

The RM6 offers a choice of solutions to make 2, 3 or 4 directional connections

- with line protection by 630A circuit breakers
- with network switching by switch disconnectors
- with integrated power supply telecontrol devices.

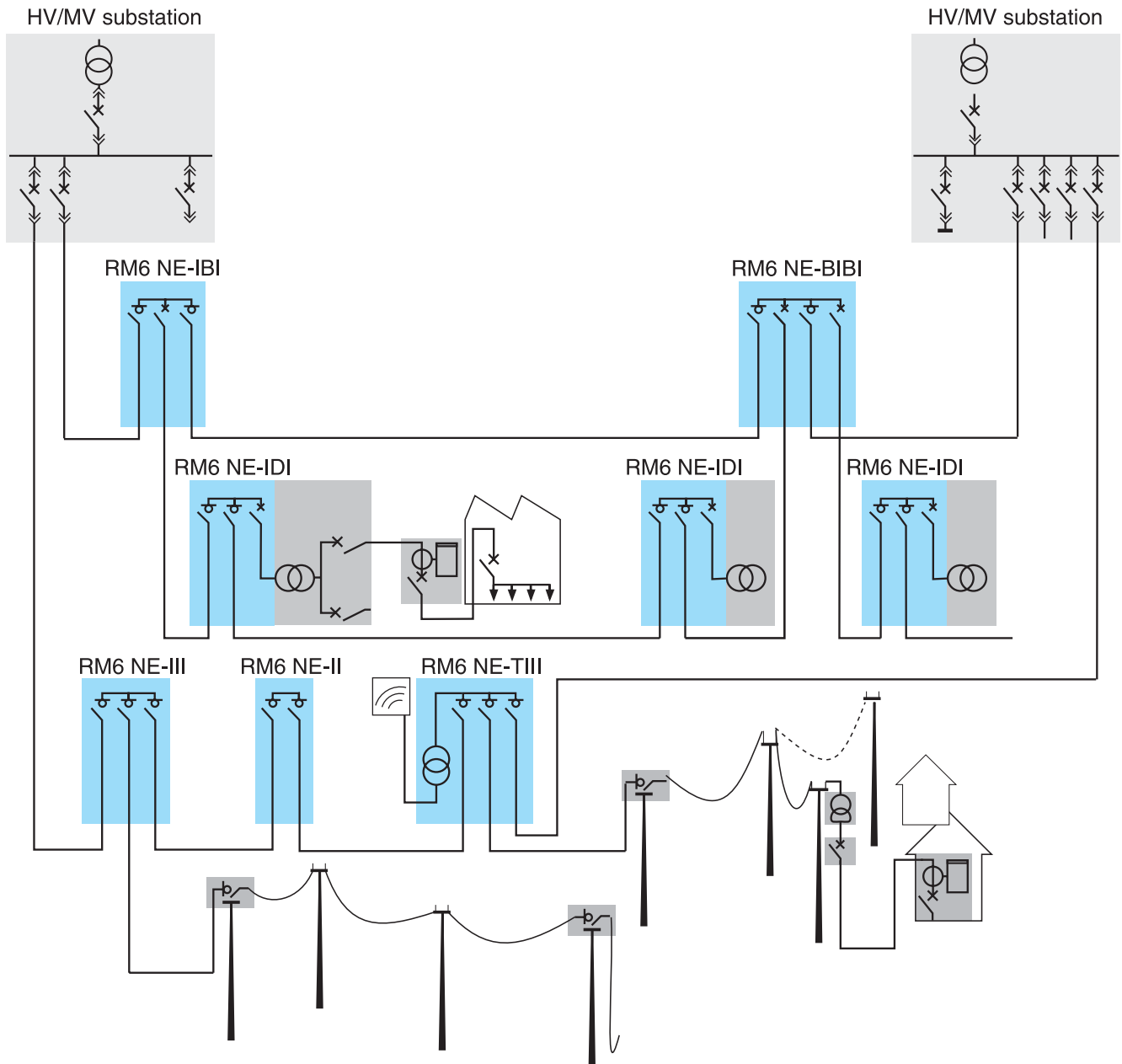

The new RM6 generation benefits from the accumulated experience acquired from the 350 000 functional units that equip electrical networks in more than 50 countries in Africa, America, Asia, Europe and Australasia. With 20 local production units around the world, Schneider offer products can be made available to you in the shortest possible time.

Ring Main Unit, long experience

- 1983 : marketing launch of the first RM6 compact with integrat insulation.
- 1987 : creation of the circuit breaker version, with integrated protection unit needing no auxiliary power supply.
- 1990 : creation of the RM6 1 functional unit.
- 1994 : creation of the Network Point, integrating the RM6 and telecontrol.
- 1998 : creation of the 630A line protection integrated relay circuit breaker and launch of an RM6 range that is extensible on site.

1983



1987



1998



Advantages of a proven design

RM6 switchgear

■ Ensures personal safety:

- internal arc withstand in conformity with IEC 60298, attachment AA
- visible earthing
- 3 position switchgear for natural interlocking
- dependable position indicating devices

■ Is insensitive to the environment:

- stainless steel tank, degree of protection IP67
- disconnectable, sealed, metallized fuse chambers

■ Is of approved quality:

- conforms to national and international standards
- ISO 9001 certification for design and ISO 9002 certification for production
- benefits from the experience accumulated from 350 000 functional units installed world-wide.

■ Respects the environment:

- end-of-life gas recovery possible
- ISO 14001 approved production site

■ Is simple and rapid to install:

- front cable connections at the same height
- easily fixed to the floor with 4 bolts

■ Is economical:

- from 1 to 4 functional units, integrated within the same metal enclosure for which insulation and breaking take place in SF6 gas.
- lifetime of 30 years

■ Has maintenance free live parts:

- in conformity with IEC 60298, attachment FF, pressure system, sealed for life.

Choosing RM6 offers you the experience of a world leader in the field of Ring Main units.

A 630 A circuit breaker, to reinforce the power supply safety of your lines

One of the means by which a power distributor can improve service quality in the network and lower installation costs, is to set up a two-level structure with a main ring distributing power to secondary rings connected to MV/LV transformers.

The RM6 range 630A circuit breaker has been designed to provide the protection for this intermediate level.

With its independent protection sequence, it detects a cable fault (either phase to phase or zero sequence) and instantly isolates it.

The VIP 300 protection relay, which is in complete conformity with IEC 60255 recommendations, offers a complete range of protection curves in order to adapt to different discrimination needs with the main protection upstream.

With this ring protection circuit breaker

- You benefit from our experience in independent protection systems and low pressure breaking technologies.
- You are provided with switchgear which, motorized either as a factory-built feature or as an on-site upgrade option without interrupting service, is designed to integrate perfectly into the telecontrol of up-to-date distribution networks.



A new range that is extensible on site

When harsh climatic conditions or environmental restrictions make it necessary to use compact switchgear, but the foreseeable evolution of the power distribution network makes it necessary to provide for future changes, RM6 offers a range of extensible switchgear.

The addition of one or more functional units can be carried out by simply adding stand-alone modules that are connected to each other at busbar level by directed field bushings.

This very simple operation can be carried out on-site:

- without handling any gas,
- without any special tooling,
- without any particular preparation of the floor.

The only technical limitation to the evolution of an extensible RM6 switchboard is therefore that of keeping to the rated current of the busbar.



Milenium 8100

Continuity of service guaranteed by an overall telecontrol offer

The efficiency of a distribution network can be greatly improved by the use of telecontrol systems, which enable you to:

- achieve a noticeable decrease in outage time, due to monitoring and control of network equipment, thus improving service quality,
- optimize network operation, due to monitoring in real time. The network can be operated closer to its limits, in greater safety, and certain investments can be deferred or optimized in complete safety,
- reduce operating costs by simplifying and accelerating the search for faults and allowing much faster reconfiguration.

Schneider offers you a complete solution, including:

- the Milenium 8100 and 8200 range, MV network control systems,
- the Easergy T200 telecontrol interface,
- MV switchgear that is adapted for telecontrol.

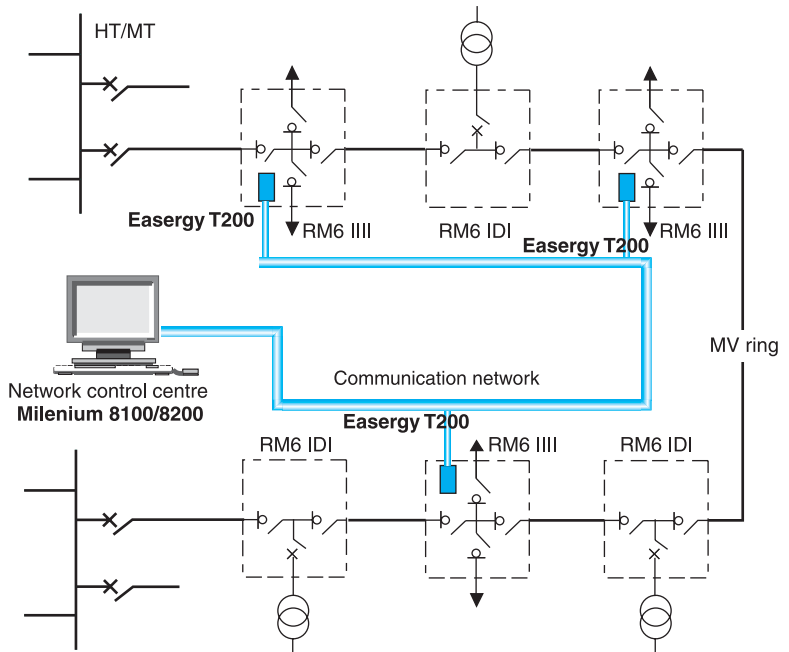

Milenium 8100 and Milenium 8200

offer you definite advantages

A range of compatibles solutions:

- Milenium 8100 is an entry-level solution.
- Milenium 8200 offers higher performance capabilities and functions.

Powerful functions:

- rapid identification of faults,
- help with reconfiguring the network after an outage,
- analysis of consumption and the network load status...

As far as telecontrol is concerned, you benefit from:

- an investment for the future, due to a secure upgrade path,
- the power of the operator interface (normally available only on much larger systems),
- complete control of the maintenance of your system, due to the use of simple, powerful tools.

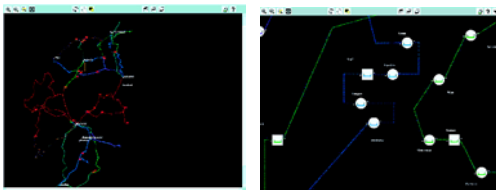

Thanks to the alayered structure and the configurable display of devices, you can have different views of your network.



Easergy T200: an interface designed for telecontrol of MV networks

Easergy T200 is a "plug and play" or multifunction interface that integrates all the functional units necessary for remote supervision and control of the RM6:

- acquisition of the different types of information: switch position, fault detectors, current values...
- transmission of switch open/close orders,
- exchanges with the control center.

Required particularly during outages in the network, Easergy T200 is of proven reliability and availability, being able to ensure switchgear operation at any moment. It is simple to set up and to operate.



Local informations



Monitoring and control

Functional unit designed for the Medium Voltage network

- Easergy T200 is designed to be connected directly to the MV switchgear, without requiring a special converter.
- It has a simple front plate for local operation, which allows management of electrical rating mechanisms (local/remote switch) and display of information concerning switchgear status.
- It has an integrated MV network fault current detection system (overcurrent and zero sequence) with detection set points that can be configured channel by channel (current value and fault current duration).



Power supply



Polarized connectors

Medium Voltage switchgear operating guarantee

- Easergy T200 has undergone severe MV electrical stress withstand tests.
- It is a backed up power supply which guarantees continuity of service for several hours in case of loss of the auxiliary source, and supplies power to the Easergy T200 and the MV switchgear motor mechanisms.

Ready to plug

- Easergy T200 is delivered with a kit that makes it easy to connect the motor mechanisms and collect measurements.
- The telecontrol cabinet connectors are polarized to avoid any errors during installation or maintenance interventions.
- Current measurement acquisition sensors are of the split type, to facilitate their installation.



Split sensors

Position of the RM6

RM6 switchgear is perfectly adapted to the telecontrol context, thanks to options such as:

- integrated voltage transformer, for independent supply to auxiliaries,
- Easergy T200 telecontrol interface,
- electrical rating mechanism,
- auxiliary fault and position indication contacts,
- current sensors for fault detection.



Description of RM6 switchgear

RM6 switchgear comprises 1 to 4 integrated, low dimension functional units.

This self-contained, totally insulated unit comprises:

- a stainless steel, gas-tight metal enclosure, sealed for life, which groups together the live parts, switch-disconnector, earthing switch, fuse switch or the circuit breaker,
- one to four cable compartments with interfaces for connection to the network or to the transformer,
- a low voltage compartment,
- an electrical operating mechanism compartment,
- a fuse chamber compartment for fused switch-disconnectors or fuse switches.

The performance characteristics obtained by the RM6 meet the definition of a "sealed pressure system" laid down in the IEC recommendations.

The switch-disconnector and the earthing switch offer the operator all necessary usage guarantees:

Tightness

The enclosure is filled with SF6 at a 0.2 bar gauge pressure. It is sealed for life after filling. Its tightness, which is systematically checked at the factory, gives the switchgear an expected lifetime of 30 years. No maintenance of live parts is necessary with the RM6 breaking.

Switch disconnector

Electrical arc extinction is obtained using the SF6 puffer technique.

Circuit breaker

Electrical arc extinction is obtained using the rotating arc technique plus SF6 auto-expansion, allowing breaking of all currents up to the short-circuit current.

Network switch-disconnector	I	
Transformer feeder fuse-switch combination	Q	
Transformer feeder 200 A circuit breaker	D	
Line feeder 630 A circuit breaker	B	
Telecontrol power supply transformer	T	

Selection of functions

The range offers the user a selection of **non extensible** RM6 combinations with 1, 2, 3 and 4 functional units.

Adaptable to all requirements, this makes it possible to choose the transformer feeder protection:

- switch-disconnector combined with fuses,
- or 200A circuit breaker.

It also allows the protection of secondary MV rings using 630A circuit breakers.

Most of this switchgear exists in versions that are **extensible on the right or on both sides**, in order to provide for future development of the network.

Designation of different switchgear

type of tank

- NE: non extensible
- RE: extensible on the right
- DE: module that is extensible on the right or the left

function configuration

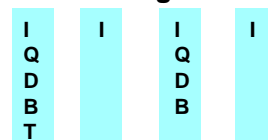

Example of designation

RM6 NE-IQI
RM6 RE-DIDI

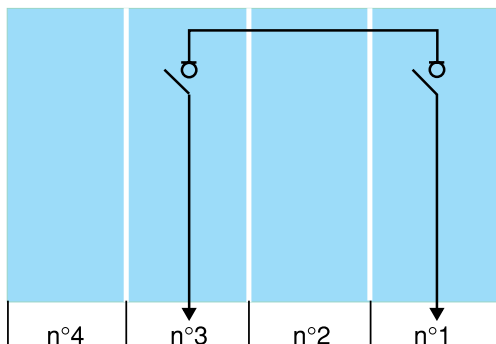

Table of electrical characteristics

Rated voltage (kV)		12/17.5		24	
insulation level					
industrial frequency	50 Hz 1 mn (kV eff.)	28/38		50	
impulse	1,2/50 µs (kV crête)	75/95		125	
Network-switch					
rated current (A) ⁽¹⁾		630	630	400	630 630
breaking capacity (A) ⁽¹⁾	charging current	630	630	400	630 630
	earth leakage fault	95	95	95	95 95
	no-load cable	30	30	30	30 30
short-time withstand current (kA eff. 1 s) ⁽²⁾		21	25 ⁽⁴⁾	16	16 20
making capacity of switch and earthing switches (kA peak)		52.5	62.5 ⁽⁴⁾	40	40 50
Transformer feeder					
rated current (A)		200	200	200	200 200
off-load transformer laking capacity (A)		16	16	16	16 16
Fuse-switch					
short-circuit breaking capacity (kA) ⁽³⁾		21	25 ⁽⁴⁾	16	16 20
making capacity (kA peak) ⁽³⁾		52,5	62.5 ⁽⁴⁾	40	40 50
Circuit breaker					
short-circuit breaking capacity (kA)		21	25 ⁽⁴⁾	16	16 21
making capacity (kA peak)		52.5	62.5 ⁽⁴⁾	40	40 52.5
Line protection feeder					
rated current (A)		630		630	
short-circuit breaking capacity (kA)		21	25 ⁽⁴⁾	16	21
making capacity (kA peak)		52.5	62.5 ⁽⁴⁾	40	52.5

1) In accordance with IEC guidelines, these characteristics are valid for ambient temperatures of between -25°C and +40°C (class: -25°C).

For higher temperatures, the permissible current (in A) becomes:

Temperature	40°C	45°C	50°C	55°C
Indoor installation	400	400	400	355
	630	575	515	460

(2) For 3 sec. thermal withstand, please consult us.

(3) Prospective value, the actual current being limited by the fuse.

(4) Limited to 12 kV.

Standards

RM6 meets international standards:

Normal operating conditions for indoor switchgear as laid down by **IEC 60694 : Common specifications for high-voltage switchgear and controlgear standards.**

■ **Ambient temperature:** class -25 indoors

- lower than or equal to 40°C.
- lower than or equal to 35°C on average over 24 hours.
- greater than or equal to - 25°C.

■ **Altitude:**

- lower than or equal to 1000 m,
- above 1000 m, and up to 3000 m, with directed field connections.

■ **Breaking capacity:**

RM6 switch-disconnectors are "**E3/M1 class switch-disconnectors**" which are in conformity with **IEC standard 60265, i.e., : High voltage switches for rated voltages of 52kV and above.**

- 100 CO cycles at rated current and 0.7 p.f.,
- 1000 mechanical opening operations.

200 and 630 A circuit breakers are designed to carry out:

IEC 62271-100 (to replace IEC 60056) : High-voltage alternating current circuit breakers.

- 2000 mechanical opening operations, in conformity with IEC standard 60056,
- 3 OC cycles at short-circuit current.

Other standards :

IEC 60298 : A.C. metal-enclosed switchgear and controlgear for rated voltage above 1kV and up to including 52kV.

IEC 60420 : High voltage alternatif current switch-fuse combinations.

IEC 60255 : Electrical relays.

IEC 62271-102 (to replace IEC 60129) : High-voltage alternating current disconnectors and earthing switches.

Transformer protection by fuse-switch combinations

Non-extensible switchgear

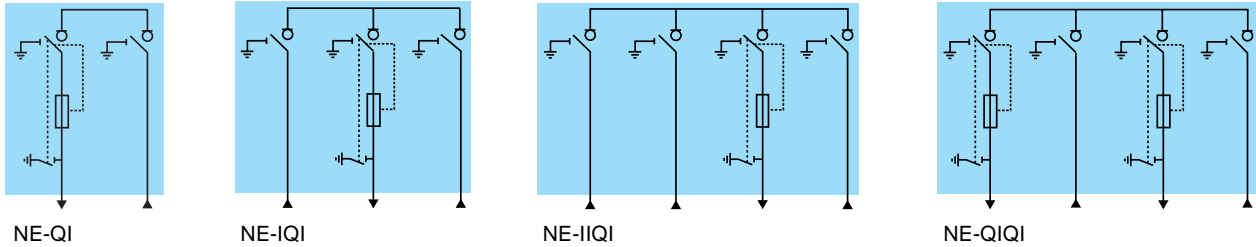

Extensible switchgear

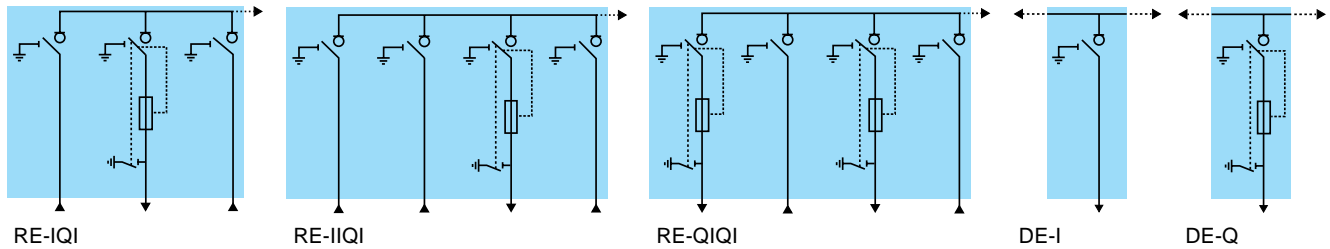

Transformer protection by 200 A circuit breaker

Non-extensible switchgear

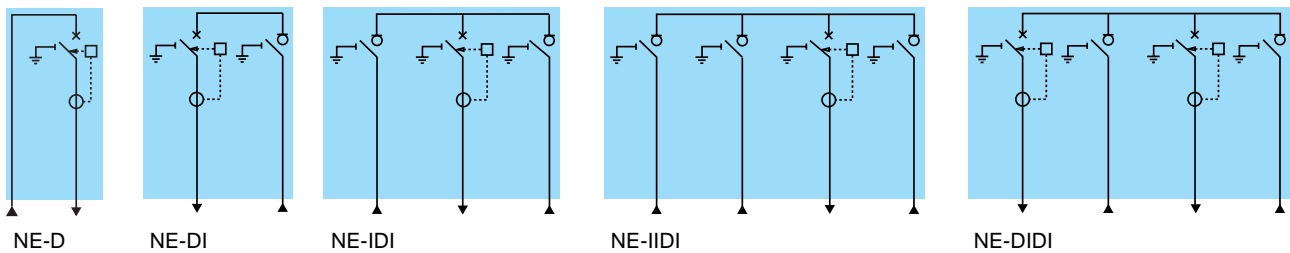

Extensible switchgear

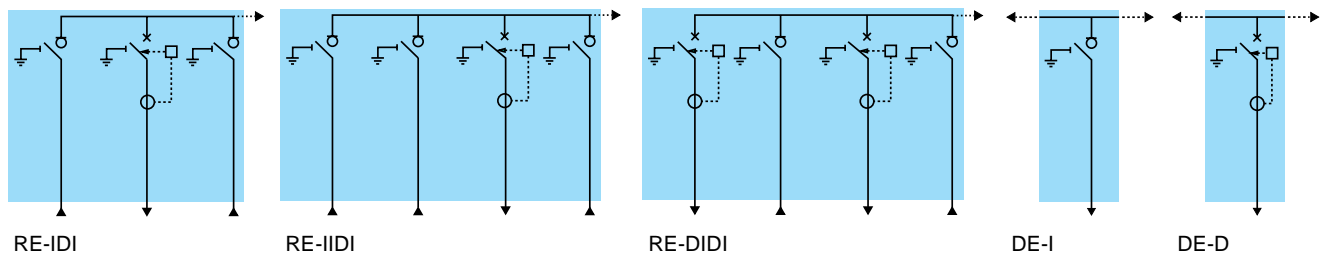

Network points with switch disconnector

Non extensible switchgear

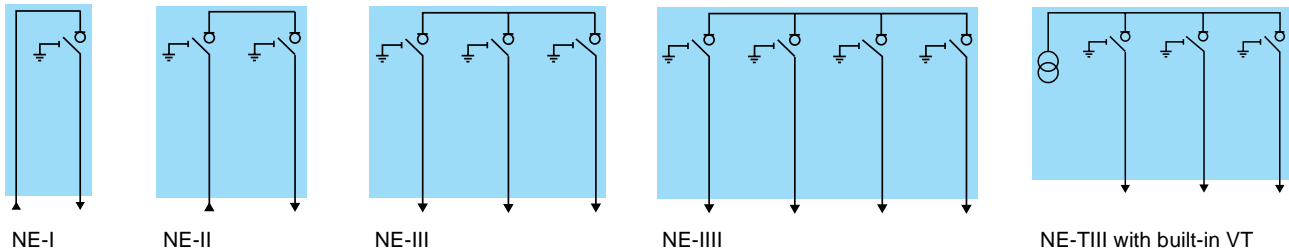

Extensible switchgear

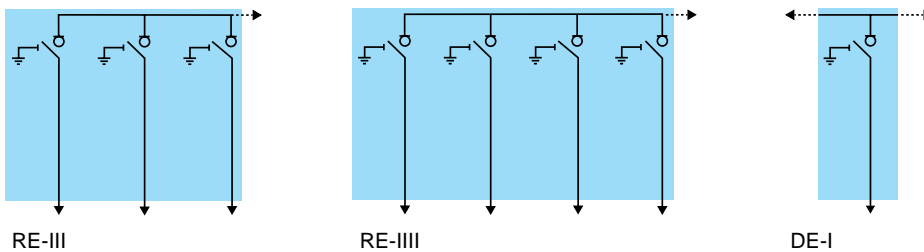

Network points with 630 A circuit breaker

Non extensible switchgear

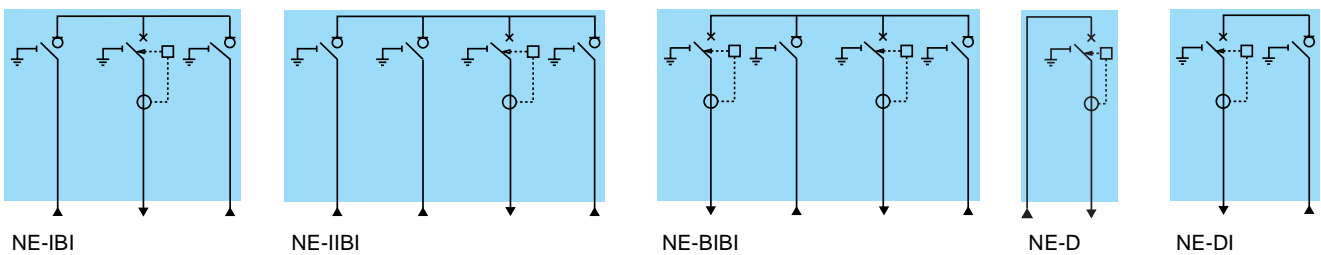

Extensible switchgear

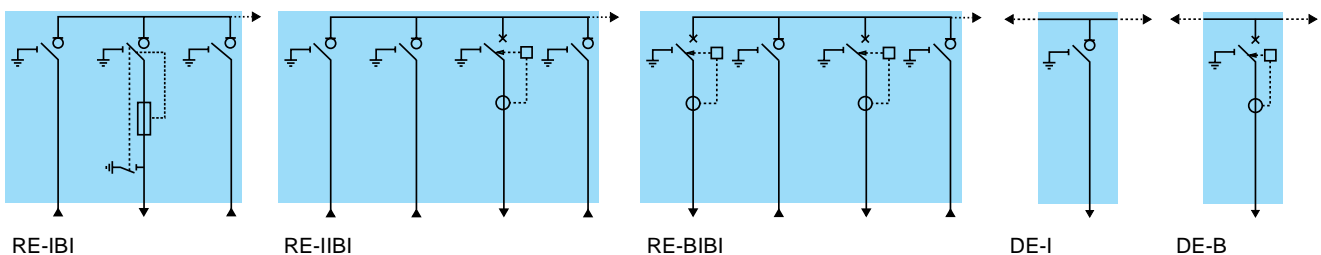

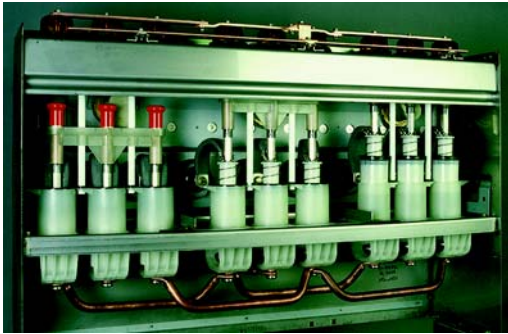

3 stable position switch

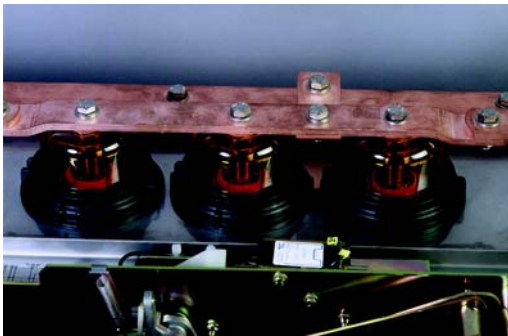

Switchgear

Switch-disconnectors and circuit breakers have similar architecture:

- a **moving contact assembly with 3 stable positions** (closed, open and earthed) moves vertically (see sketch). Its design makes simultaneous closing of the switch or circuit breaker and the earthing switch impossible,
- the **earthing switch** has a short-circuit making capacity, as required by the standards,
- the RM6 combines both the **isolating** and interrupting functions,
- the earth collector has the correct dimensions for the network,
- access to the cable compartment can be interlocked with the earthing switch and/or the switch or circuit breaker.

Reliable operating mechanisms

The electrical and mechanical operating mechanisms are located behind a front plate displaying the mimicking diagram of the switchgear status (closed, open, earthed):

- **closing:** the moving contact assembly is manipulated by means of a fast-acting operating mechanism. Outside these manipulations, no energy is stored. For the circuit breaker and the fuse-switch combination, the opening mechanism is charged in the same movement as the closing of the contacts.
- **opening:** opening of the switch is carried out using the same fast-acting mechanism, manipulated in the opposite direction. For the circuit breaker and fuse-switch combination, opening is actuated by:
 - a pushbutton,
 - a fault.
- **earthing:** a specific operating shaft closes and opens the earthing contacts. The hole providing access to the shaft is blocked by a cover which can be opened if the switch or circuit breaker is open, and remains locked when it is closed.
- **switchgear status indicators:** are placed directly on the moving contact assembly operating shafts. They give a definite indication of the position of the switchgear (attachment A of IEC standard 60129).
- **operating lever:** this is designed with an anti-reflex device which prevents any attempt to immediately reopen the switch-disconnector or the earthing switch after closing.
- **padlocking facilities:** 1 to 3 padlocks can be used to prevent:
 - access to the switch or circuit breaker operating shaft,
 - access to the earthing switch operating shaft,
 - operation of the opening pushbutton.

Earthing display

- **earthing switch closed position indicators:** these are located on the upper part of the RM6. They can be seen through the transparent earthing covers, when the earthing switch is closed.

Internal arc withstand

The robust, reliable and environmentally insensitive design of the RM6 makes it highly improbable that a fault will appear inside the switchgear. Nevertheless, in order to ensure maximum personal safety, the RM6 is designed to withstand an internal arc supplied by a rated short-circuit current for 1 second, without any danger to the operator. Accidental overpressure due to an internal arc is limited by the opening of the safety valve, at the bottom of the metal enclosure. The gas is released to the rear of the RM6 without affecting conditions in the front. After standard testing carried out for 20 kA, 1s, the device meets the six criteria defined by **appendix AA of IEC 60298**.



Insensitivity to the environment

Complete insulation

- A metal enclosure made of stainless steel, which is unpainted and gas-tight (IP67), contains the live parts of the switchgear and the busbars;
 - Three sealed fuse chambers, which are disconnectable and metallized on the outside, insulate the fuses from dust, humidity...
 - Metallization of the fuse chambers and directed field terminal connectors confines the electrical field in the solid insulation.
- Taken together, the above elements provide the **RM6 with genuine total insulation** which makes the switchgear completely insensitive to environmental conditions, dust, extreme humidity, temporary soaking. (IP67: immersion for 30 mn, as laid down in IEC standard 60529, § 14.2.7).



Operating safety

Cable insulation test

In order to test cable insulation or look for faults, it is possible to inject a direct current of up to 42 kVdc for 15 minutes through the cables via the RM6, without disconnecting the connecting devices.

The earthing switch is closed and the moving earthing connection is opened in order to inject the voltage via the "earthing covers". This system, a built-in feature of the RM6, requires the use of injection fingers (supplied as an option).



Voltage indicator lamps

A device (supplied as an option) on all functional units makes it possible to check the presence (or absence) of voltage in the cables.

Two types of indicator can be proposed according to network operating habits:

- A device with built-lamps, of the VPIS type (Voltage Presence Indicating System) complying with standard IEC 61958,



- or a system with separate luminous modules, of the VDS type (Voltage Detection System) complying with standard IEC 61243-5.

Fuse dimensions

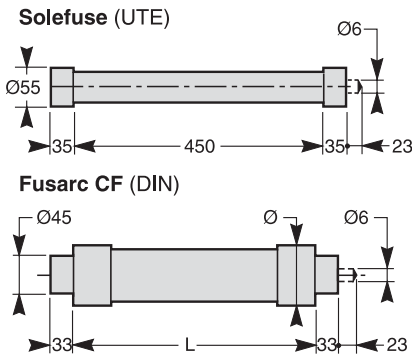

Ratings for fuses for transformer protection depend, among other points, on the following criteria:

- service voltage,
- transformer rating,
- thermal dissipation of the fuses,
- fuse technology,

Two types of fuse may be installed:

- **Solefuse type:** according to UTE NFC 64.210 standard, with or without striker,
- **Fusarc CF type:** according to DIN 43.625 dimensional standard, with or without striker.

Example (using the selection table below) general case, for protection of a 400 kVA transformer at 10 kV, either **Solefuse** fuses with a rating of 63 A or **Fusarc CF** fuses with a rating of 50 A are chosen.

For fuses of other manufacturers, please consult us.

rated voltage (kV)	rating (A)	L (mm)	Ø (mm)	mass (kg)
12	10 to 20	292	50.5	1.2
	25 to 40	292	57	1.5
	50 to 100	292	78.5	2.8
24	10 to 20	442	50.5	1.6
	25 to 40	442	57	2.2
	50 to 63	442	78.5	4.1
	80 to 100	442	86	5.3

Fuse replacement

ICE and UTE recommendations stipulate that when a fuse has **blown, all three fuses must be replaced.**

Selection table

(Rating in A, no overload, -25 °C < θ < 40 °C)

fuse type	operating voltage (kV)	transformer rating (kVA)															rated voltage (kV)
		50	75	100	125	160	200	250	315	400	500	630	800	1000	1250	1600	
UTE NFC standards: 13.100, 64.210																	
Solefuse																	
	5.5	16	31.5	31.5	63	63	63	63	63	63							7.2
	10		16	16	31.5	31.5	31.5	63	63	63	63						24
	15		16	16	16	16	16	43	43	43	43	43	63				
	20		16	16	16	16	16	16	43	43	43	43	43	63			
general case, CEI 60282.1 standards, CEI 60420 and DIN 43.265 standard																	
Fusarc CF																	
	3	20	31.5	40	50	50	63	80	100	125	160*						12
	3.3	20	25	40	40	40	63	80	80	125	160*						
	4.2	20	25	25	40	50	50	63	80	80	100	125	160*				
	5.5	16	20	25	25	40	40	50	63	80	80	100	125	160*			
	6	16	20	25	25	31.5	40	50	50	63	80	100	125	160*			
	6.6	10	20	25	25	31.5	40	50	50	63	63	80	100	125	160*		
	10	10	10	16	20	25	25	31.5	40	50	50	63	80	100	125		
	11	10	10	16	20	20	25	25	40	40	50	50	63	80	100	125	
	13.8	10	10	10	16	16	20	25	31.5	40	40	50	50	63	100		24
	15	10	10	10	10	16	20	25	31.5	31.5	40	50	50	63	80	100	
	20	10	10	10	10	16	16	20	25	25	31.5	40	40	63	63	80	100
	22	10	10	10	10	10	16	16	20	25	31.5	40	40	50	63	80	100

(*) please consult us.
For all fuse ratings not included in the table, please consult us.
Please consult us for overloads or operation over 40°C.



VIP 30

VIP 35

In contrast to fuses, the circuit breaker has no minimum breaking current, which means that it is particularly well-adapted to transformer protection.

Protection system

The protection system operates without an auxiliary power supply, and includes:

- 3 transformers with integrated toroids on the transformer feeder bushings,
- 1 VIP 30 or VIP 35 electronic relay,
- 1 release,
- 1 test connector to check whether the protection unit is operating correctly, using the VAP 6 unit.

VIP 30 and VIP 35 self-powered protection relays

VIP 30 and VIP 35 are self-powered relays, requiring no auxiliary power supply, which are fed by current sensors, activating a MITOP release.

VIP30 protects against phase to phase faults.

VIP35 protects against phase to phase faults and earth faults.

Description

- the relays are assembled in a housing, and the front faces are protected a transparent cover. The whole assembly has a degree of protection of IP54,
- settings are made on the front, using rotary switches,
- the phase operating current is adjusted directly according to the transformer rating and the operating voltage,
- the earth current set point is adjusted according to the network characteristics.

Phase protection

- phase protection is provided by an IDMT set point which operates as of 1.2 times the operating current (Is). VIP 30 and VIP 35 phase protections are identical.

Earth protection

- earth fault protection operates with measurement of the residual current carried out using the sum of the secondary currents of the sensors,
- earth protection operates in definite time: both its set point and time delay are adjustable.

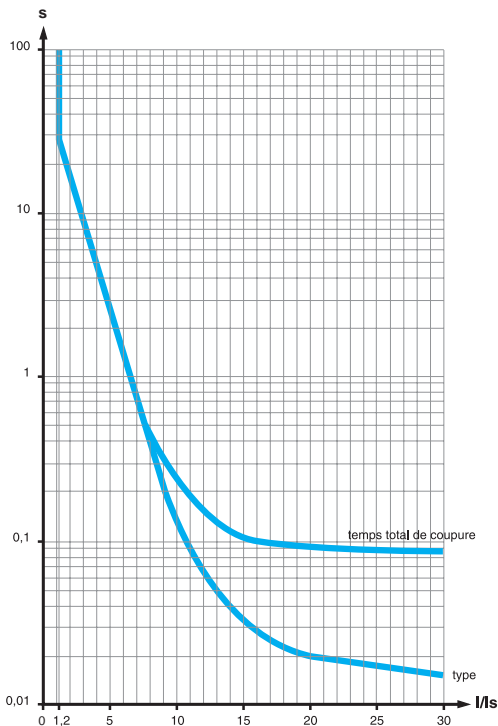

The curve represent the relay intervention time, to which 70 ms must be added to obtain the breaking time.

Rated protection current setting selection

operating voltage (kV)	transformer rating (kVA)																rated voltage (kV)			
	50	75	100	125	160	200	250	315	400	500	630	800	1000	1250	1600	2000		2500	3000	
3	10	15	20	25	36	45	55	68	80	140	140	170	200							12
3.3	10	15	18	22	28	36	45	56	70	90	140	140	200							
4.2	8	12	15	18	22	28	36	45	56	70	90	140	140	200						
5.5		8	12	15	18	22	28	36	46	55	68	90	140	140	200					
6			10	12	18	20	25	36	46	55	68	80	140	140	200	200				
6.6			10	12	15	18	22	28	36	45	56	70	90	140	140	200				
10				8	10	12	15	20	25	30	37	55	68	80	140	140	170	200		
11					10	12	15	18	22	28	36	45	55	68	90	140	140	170		
13.8					8	10	12	15	18	22	28	36	46	55	68	90	140	140	24	
15						8	10	15	18	20	25	36	45	55	68	80	140	140		
20							8	10	15	20	25	30	37	45	55	68	80	140		
22								8	10	12	15	18	22	28	36	45	55	68	80	



VIP 300

The 630 A circuit breaker has been designed to protect medium voltage feeders as near to the fault as possible. The protection unit is identical to that of the 200 A circuit breaker, with a VIP 300 relay adapted to network protection.

VIP 300 self-powered protection relay

- VIP 300 protects against phase to phase faults and earth faults. The choice of tripping curves, and the multiplicity of settings enable it to be used with a wide variety of discrimination plans.
- VIP 300 is a self-powered relay which obtains its power supply from current sensors. It does not need an auxiliary power supply. It actuates a release.

Description

The operating principle of the protection unit is the same as for the VIP 300 and VIP 35 relays.

Phase protection

- Phase protection has two independently adjustable set points:
 - either an IDMT or definite low set point can be selected. The IDMT curves are in conformity with the IEC 60255-3 standard. They are of the inverse, very inverse and extremely inverse type,
 - the high set point is a definite time one.

Earth protection

- Earth fault protection operates with measurement of the residual current carried out using the sum of the secondary currents of the sensors.
- As with phase protection, earth protection has two independently adjustable set points.

Indication

- Two indicators show the origin of tripping (phase or earth). They remain in position after the relay power supply is cut off.
- Two LED indicators (phase and earth) indicate that the low set point has been exceeded and its time delay is in progress.

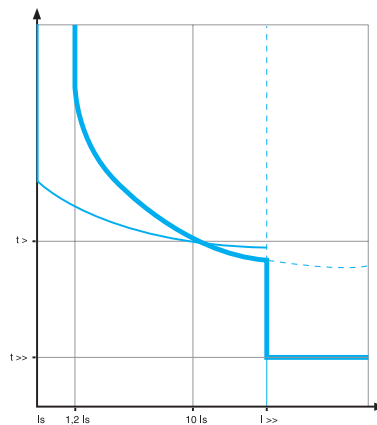

With IDMT low set point

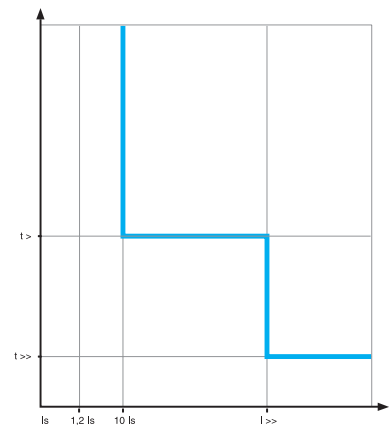

With definite time low set point

- The curves in this chapter indicate the low set IDMT tripping times for time delay settings $t >$ (or $t >$).
- The phase protection and earth protection curves are identical.
- Total breaking time (see VIP200).

SI curve

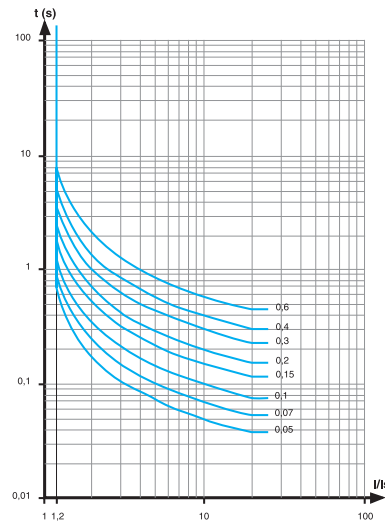

VI curve

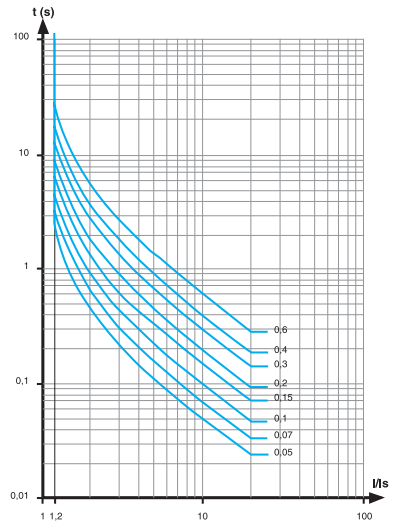

EI curve

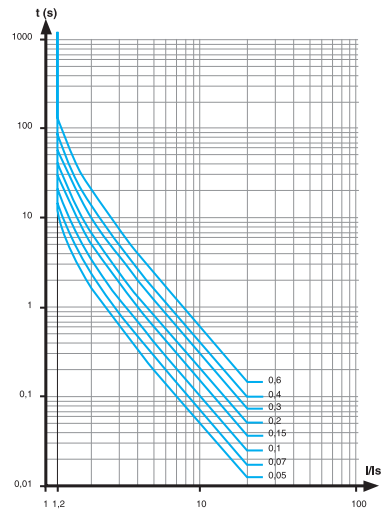

RI curve

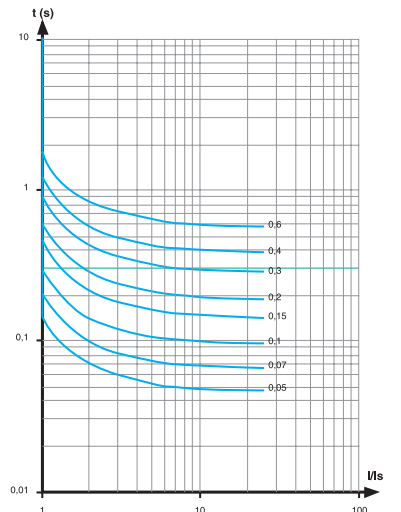

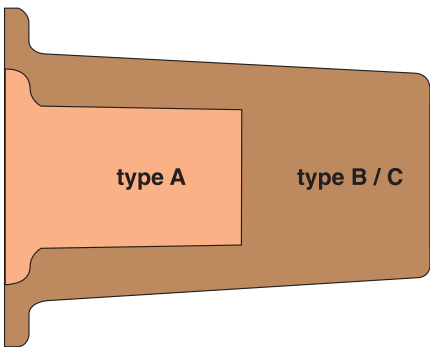

Types of connection interface

This informations must be specified for better definition of the connection interfaces.

General

- The profiles, contacts and dimensions of the RM6 connection interfaces are defined by the EN50181 standard.
- 100% of the epoxy resin interfaces undergo dielectric testing at power frequency and partial discharge tests.

Appropriateness for use

The bushings carry the electrical current from the outside to the inside of the enclosure, which is filled with SF6 gas, ensuring insulation between the live conductors and the frame.

There are 3 types of bushing, which are defined by their short-time withstand current:

type A: 200 A: 12,5 kA 1 s and 31,5 kA peak (plug-in)

type B: 400 A: 16 kA 1 s and 40 kA peak (plug-in)

type C: 630 A: 25 kA 1 s and 62,5 kA peak (disconnectable M16)

How to define the connection interface

The connection interfaces depend on specific criteria, such as:

Installation

- current rating of the connected equipment: 200, 400, 630 A
- short-time withstand current for 12.5 kA, 16 kA, 25 kA switch and circuit breaker functions
- for the fuse-switch combination function, as the short-circuit current is limited by the fuse, the connection interface will be of type A (200 A)
- minimum phase expansion length
- connection type:
 - plug in: multicontact ring
 - disconnectable: bolted
- output position: straight, elbow

Cable

- specified voltage:
 - of the cable,
 - of the network,
- type of conductor:
 - aluminium,
 - copper,
- cross section in mm²
- insulation diameter
- cable composition:
 - single-core,
 - 3-core,
- insulation type:
 - dry,
 - paper impregnated (non-draining type)
- type of screen
- armature.

Standard cable compartment equipment

- a closing panel,
- cable binding,
- cable grounding connections.

Options:

- panel with hood for display of liquid type overcurrent indicators installed around the cables,
- panel for connectors with lightning arrestor,
- interlocking which prohibits access to the connection compartment when the earthing switch is open,
- interlocking which prohibits closing of the switch or circuit breaker when the connection compartment panel is open,
- back of compartment for single-core or 3-core cables (mandatory for non-directed field connections),
- cable compartment internal arc withstand up to 16 kA 1s.



For network switch-disconnectors

Dry single-core cable

Type B bushing - 400 A, limited to 16 kA/1s

Directed field plug-in connector

performance	connection	supplier	reference	cross section	remarks
7.2 to 10 kV 400 A-95 kV impulse	plug-in	Elastimold	400 LR	70 to 240	limited to Us = 10 kV
24 kV 400 A-125 kV impulse	plug-in	Pirelli	FMCE 400	70 to 300	
		Elastimold	K400LR	35 to 240	
		Pirelli	FMCE 400	70 to 300	
		Kabeldon	SOC 630	50 to 300	

For network switch-disconnectors and line protection circuit breakers

Dry single-core cable

Type C bushing - 630 A

Directed field disconnectable connector

performance	connection	supplier	reference	cross section	remarks
7.2 to 10 kV 630 A-95 kV impulse	disconnectable	Elastimold	440 TB	70 to 240	
7.2 to 24 kV 630 A-125 kV impulse	disconnectable	Pirelli	FMCTs 400	70 to 300	
		Elastimold	K400TB	35 to 240	
		Kabeldon	SOC 630	50 to 300	
		F&G/NKT cable	CB 24-630	16 to 300	

Dry single and 3 core cable

Type C bushing - 630 A

Non-directed field disconnectable connector

performance	connection	supplier	reference	cross section	remarks
7.2 to 17.5 kV 630 A-95 kV impulse	heat shrinkable	Raychem	EPKT+EAKT	16 to 300	
	insulating boots	Sigmaform	Q-CAP	16 to 300	
		Kabeldon	SOC 630	50 to 300	completed by a kit for three-pole cable
		Pirelli	ELPB12	50 to 300	limited to 75 kV impulse
	simplified disconnectable	Raychem	RICS - EPKT	25 to 300	
		Euromold	15TS-NSS	50 to 300	limited to Us = 12 kV
24 kV 630 A-125 kV impulse	simplified disconnectable	Raychem	RICS - EPKT	25 to 300	
		F&G/NKT cable	AB 24-630	16 to 300	

For network switch-disconnectors and line protection circuit breakers

Single core cable, paper impregnated, non draining type

Type C bushing - 630 A

Non-directed field disconnectable connector

performance	connection	supplier	reference	cross section	remarks
7.2 to 17.5 kV	disconnectable	Pirelli	FMCp400	95 to 300	
630 A-95 kV impulse	insulating boots	Kabeldon	SOC	25 to 300	
		Pirelli	ELPB12	50 to 300	limited to 75 kV impulse
	simplified disconnectable	Raychem	RICS - EPKT	25 to 300	
	heat shrinkable	Raychem	EPKT+EAKT	95 to 300	
24 kV	disconnectable	Pirelli	FMCp 1c	95 to 300	
630 A-125 kV impulse	simplified disconnectable	Raychem	RICS - EPKT	25 to 300	

Three core cable, paper impregnated, non-draining type

Type C bushing - 630 A

Non-directed field disconnectable connector

performance	connection	supplier	reference	cross section	remarks
7.2 to 17.5 kV	insulating boots	Kabeldon	SOC 630	25 to 300	
630 A-95 kV impulse		Pirelli	ELPB12	50 to 300	limited to 75 kV impulse
	simplified disconnectable	Raychem	RICS - EPKT	25 to 300	
	heat shrinkable	Raychem	EPKT+EAKT	16 to 300	
24 kV	simplified disconnectable	Raychem	RICS - EPKT	25 to 300	
630 A-125 kV impulse					

Single core dry cable and lightning arrester

Type C bushing - 630 A

Disconnectable connector

performance	connection	supplier	reference	cross section	remarks
7.2 to 17.5 kV	disconnectable	Raychem	RICS+EPKT	25 to 300	
630 A-95 kV impulse			RDA 12 ou 18		
	disconnectable	Elastimold	K400TB+ K400RTPA+ K156SA	35 to 300	panel with the enlarged RM6
24 kV	disconnectable	Raychem	RICS+EPKT	25 to 300	
630 A-125 kV impulse			RDA 24		
	disconnectable	Elastimold	K440TB+ K400RTPA+ K156SA	35 to 300	panel with the enlarged RM6

For transformer protection by circuit breaker

Dry single-core cable

Type A bushing: limited to 12.5 kA

Directed field plug-in connector

performance	connection	supplier	reference	cross section	remarks
7.2 to 10 kV 200 A-95 kV impulse	plug-in	Elastimold	158LR	16 to 120	
24 kV 200 A-125 kV impulse	plug-in	Pirelli	FMCE 250	16 to 120	
		Elastimold	K158LR	25 to 95	
		Pirelli	FMCE 250	16 to 120	
		F&G/NKT cable	EASW 20-250	16 to 95	with fastening flange

Dry single-core cable

Type B bushing: limited to 16 kA

Directed field plug-in connector

performance	connection	supplier	reference	cross section	remarks
7.2 to 10 kV 95 kV impulse	plug-in	Elastimold	400LR	70 to 240	
24 kV 400 A-95 kV impulse	plug-in	Elastimold	K400LR	35 to 240	
		Pirelli	FMCE 400	70 to 300	

Dry single-core cable

Type C bushing - Icc 21 kA/1 s

Directed field disconnectable connector

performance	connection	supplier	reference	cross section	remarks
7.2 to 17.5 kV 200 A-95 kV impulse Icc > 16 kA	disconnectable	Elastimold	440TB	70 to 240	limited to Us = 10 kV
			K440TB	35 to 240	
		Pirelli	FMCTs 400	70 to 300	
		F&G/NKT cable	CB 24-630	16 to 300	

Dry single-core and 3 core cable

Type C bushing - Icc 21 kA/1 s

Non-directed field disconnectable connector

performance	connection	supplier	reference	cross section	remarks
7.2 to 17.5 kV 200 A-95 kV impulse	heat shrinkable	Raychem	EPKT+EAKT	16 to 300	
		Sigmaform	Q-CAP	16 to 300	
	insulating boots	Kabeldon	SOC 630	25 to 300	
		Pirelli	ELPB12	50 to 300	limited to 75 kV impulse
	simplified disconnectable	Raychem	RICS - EPKT	25 to 300	
		Elastimold	SV412C	50 to 300	limited to Us = 10 kV
	disconnectable	F&G/NKT cable	AB 24-630	16 to 300	

For transformer protection by fuse-switch combination

Single-core cable

Type A bushing - limited to 12.5 kA 1s

Directed field plus-in connector

performance	connection	supplier	reference	cross section	remarks
7.2 to 10 kV 200 A-95 kV impulse	plug-in	Elastimold	158LR	16 to 120	T-shaped elbow
			151SR	16 to 120	straight
		Pirelli	FMCE 250	16 to 95	
7.2 to 24 kV 200 A-125 kV impulse	plug-in	Elastimold	K158LR	16 to 95	T-shaped elbow
			K151SR	25 to 95	straight
		F&G/NKT cable	EASW 20-250	16 to 95	with fastening flange, T-shaped elbow
			EASG 20-250	16 to 95	straight

Dry single-core and 3 core cable

Type A profile bushing and M8 insert - 200 A

Non-directed field disconnectable connector (*)

performance	connection	supplier	reference	cross section	remarks
7.2 to 17.5 kV 200 A-95 kV impulse	heat shrinkable	Raychem	EPKT+EAKT	16 to 150	
	insulating boots	Kabeldon	KAP70	70 max.	

(*) 520 mm plinth must be used

Installation, maintenance



Phase concordance unit

This unit is used to check phase concordance. It can be connected to any voltage indicator lamp device.



Protection relay test

- the portable VAP6 unit is connected to the circuit breaker protection relay:
 - injecting an electrical stimulus, two pushbuttons are used to check that the short-circuit and zero sequence fault current protection devices are operating
 - an extra pushbutton may be provided to inhibit tripping of the circuit breaker.



Local operation

Voltage indicator lamp

There is a voltage indicator device on network switches, circuit breakers and fuse-switch combinations, which makes it possible to check whether or not there is a voltage across the cables.

Two devices are offered:

- VDS: Voltage Detecting System
- VPIS: Voltage Presence Indication System



Short-circuit indicator

- Built into the switchgear:

Each switch can be fitted with an Alpha type short-circuit indicator (Hortsmann). If an RM6 is operated remotely, this function is integrated into the Talus 200 telecontrol interface.



- To be installed in the kiosk:

The FLAIR range is designed for the tracking of permanent faults on MV cable networks. Thanks to an ammeter or directional fault detection scheme it covers the needs of all types of MV networks. Available in weatherproof or non-weatherproof enclosures, LV battery back, DC, or battery-only power supplies, the FLAIR range is very versatile and offers more than 15 versions.

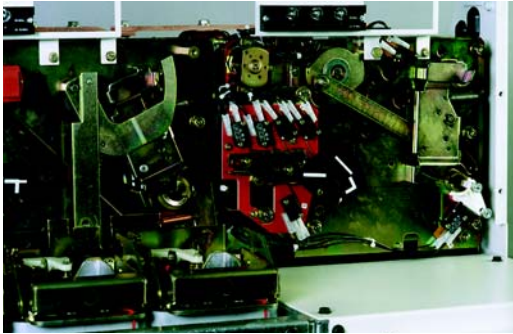

Motor mechanism

Switch operating mechanism

- the switch operating mechanism includes a space that is reserved for the installation of a geared motor. This can be installed at the factory, but it can also be installed on-site, by the customer, without de-energizing the unit, and without dismantling the operating mechanism.
- an electrical interlocking assembly prohibits any false operations. Once motorized, the RM6 integrates perfectly into a telecontrol system.



Circuit breaker operating mechanism

- circuit breaker protection functional units can be equipped with a geared motor. This can be installed at the factory, but it can also be installed on-site, by the customer, without de-energizing the unit, and without dismantling the operating mechanism.
- electrical locking prohibits any false operations, with, as an option, closing after an unacknowledged fault. Once motorized, the RM6 integrates perfectly into a telecontrol system. This option becomes particularly useful in the context of the protection of a secondary ring, with supervision by a telecontrol system.

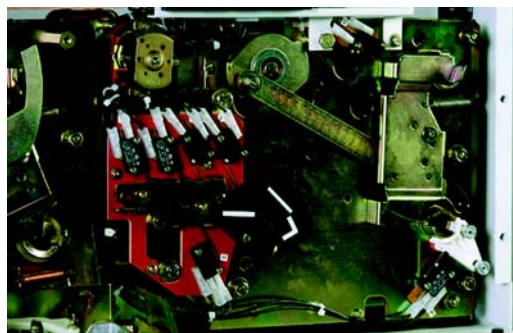

Auxiliary contacts

- Each switch or circuit breaker can be fitted with 4 auxiliary contacts with the following positions: 2 N/O and 2 N/F.
- Each earthing switch can be fitted with 1 auxiliary contact with the following position: (opening/closing).
- Each circuit breaker can be fitted with 1 fault indication auxiliary contact.
- Each fuse-switch combination can be fitted with 1 blown fuse indication auxiliary contact.



Opening release

- Each circuit breaker or fuse-switch combination can be fitted a switch-on opening release.

The markings (O, S, and X) are engraved on the keys and the locks. They are given here only as an aid to understanding of the diagrams.



Type R1 diagram

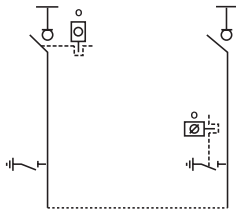

On network switches or 630 A circuit breaker feeder

Semi-crossed locking

■ Prohibits the closing of the earthing switch of the downstream switchgear unless the upstream switchgear is locked in the "open" position.

Type R2 diagram

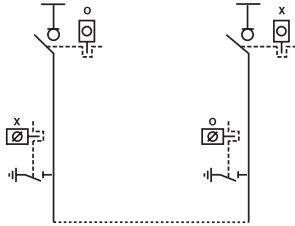

Crossed locking

■ Prohibits closing of the earthing switches unless the upstream and downstream switchgear is locked in the "open" position.

Type R7 diagram

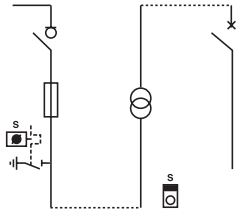

On transformer feeders

RM6 / transformer

■ Prohibits access to the transformer unless the earthing switch has been locked in the "closed" position.

Type R6 diagram

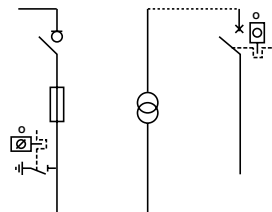

RM6 / low voltage

■ Prohibits closing of the earthing switch and access to any protection unit fuses unless the main LV circuit breaker has been locked in the "open" or "disconnected" position.

Type R8 diagram

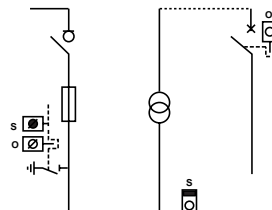

RM6 / transformer / low voltage

■ Prohibits closing of the earthing switch and access to any protection unit fuses unless the main LV circuit breaker has been locked in the "open" or "disconnected" position.

■ Prohibits access to the transformer unless the earthing switch has already been "closed".

Legend:

- | | | |
|--|--|-------------|
| | | key absent |
| | | key free |
| | | key captive |

Dimensions of non-extensibles RM6s

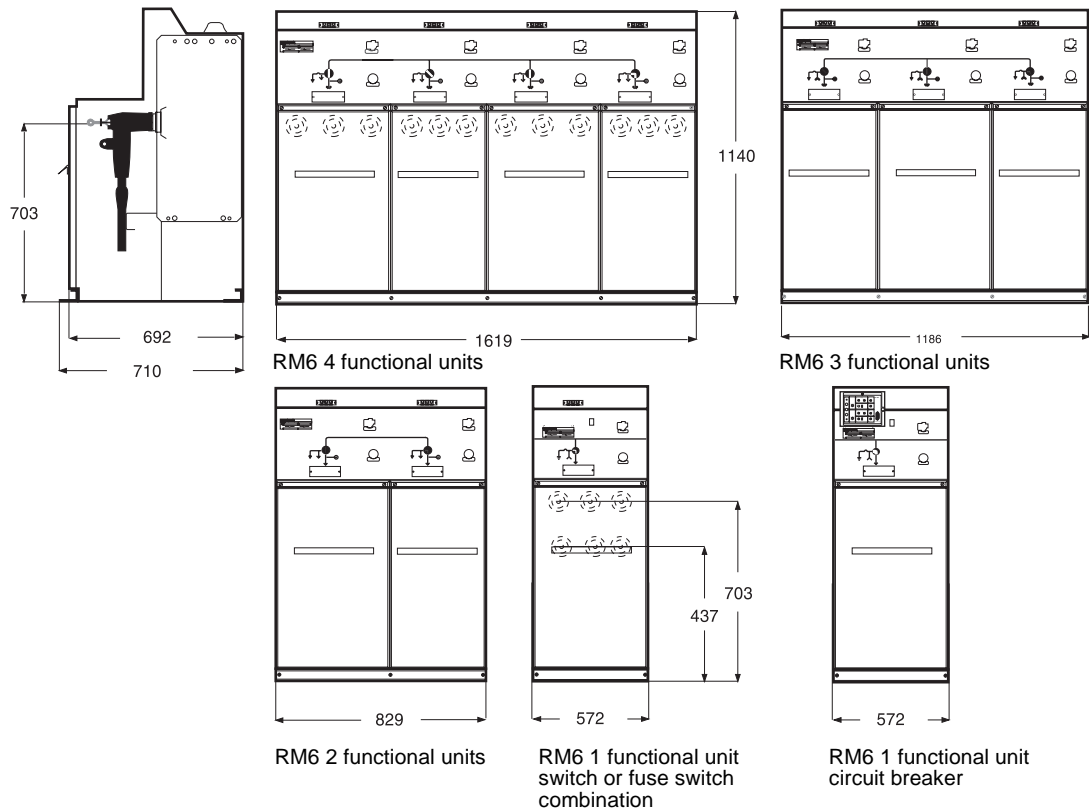

Dimensions of 3 and 4 function RM6 REs that are extensible on the right

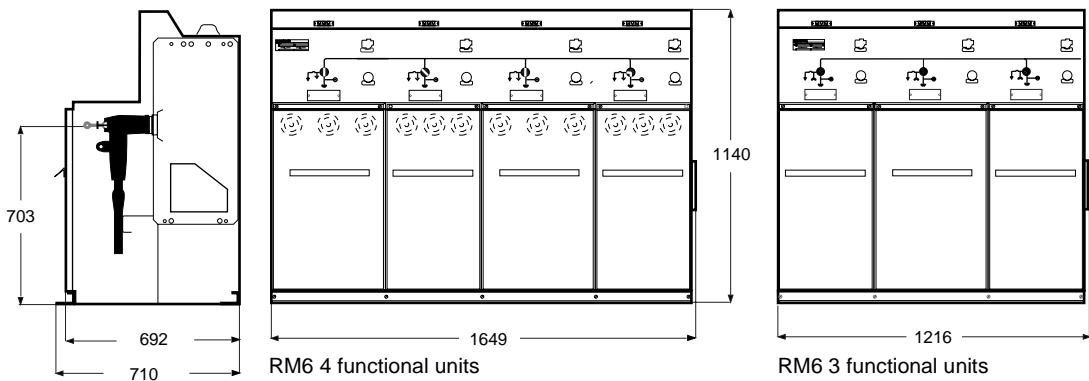

Dimensions of stand-alone RM6 modules that are extensible on both sides

With two bushing protection covers for extensibility.

RM6 1 functional unit switch or fuse-switch combination

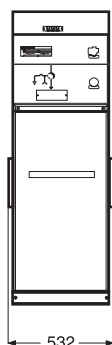

RM6 1 functional unit circuit breaker

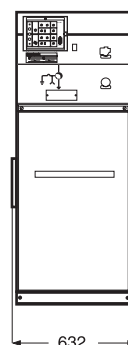

Dimensions of RM6 REs with an extension module

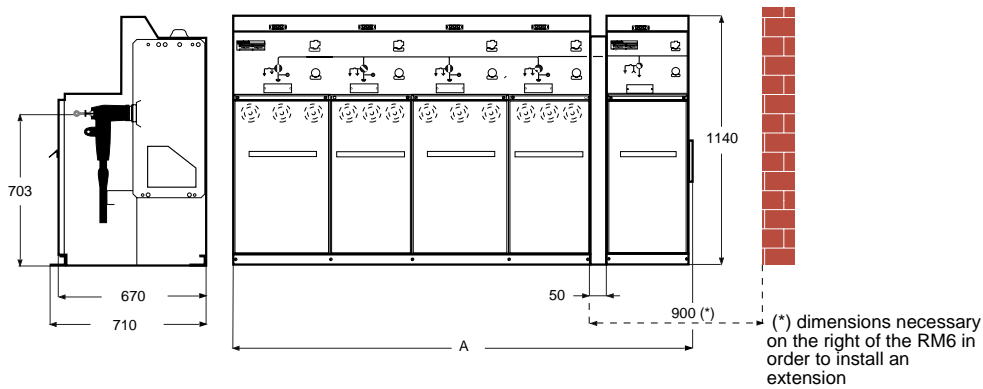

- RM6 RE 3 functional units with switch DE module: A = 1738 mm
- RM6 RE 4 functional units with switch DE module: A = 2171 mm
- RM6 RE 3 functional units with circuit breaker DE module: A = 1838 mm
- RM6 RE 4 functional units with circuit breaker DE module: A = 2271 mm

Layout

Floor mounting

The RM6 is supported by 2 metal feet with holes for mounting:

- on a flat floor fitted with trenches, passages or ducts,
- on concrete footings,
- on studs,
- on metal rails,
- etc ...

Non-extensible RM6

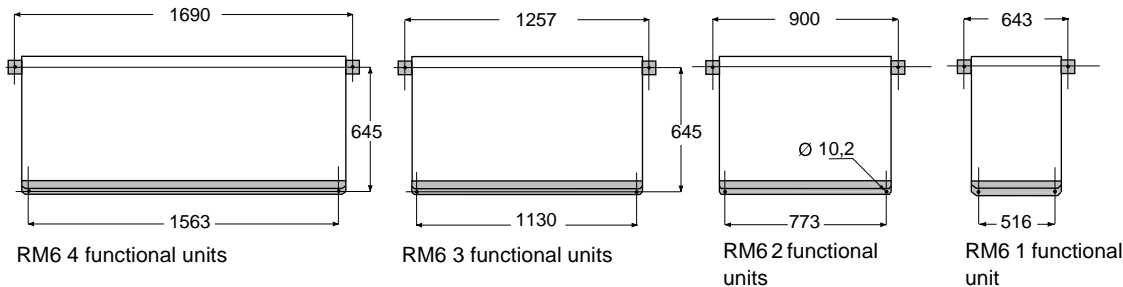

Extensible RM6

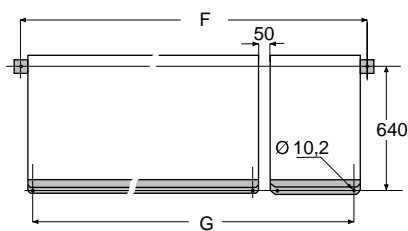

RM6 3 or 4 functional units with extensibility module

RM6 3 functional units with switch	F = 1779 mm
RM6 3 functional units with fuse-switch combination or circuit breaker	G = 1652 mm
RM6 4 functional units with switch	F = 1879 mm
RM6 4 functional units with fuse-switch combination or circuit breaker	G = 1752 mm
RM6 3 functional units with switch	F = 2212 mm
RM6 3 functional units with fuse-switch combination or circuit breaker	G = 2085 mm
RM6 4 functional units with switch	F = 2312 mm
RM6 4 functional units with fuse-switch combination or circuit breaker	G = 2185 mm

Wall mounting

There are two holes allowing the unit to be fixed on the wall as well as mounted on the floor.

Additional raising plinth

As an option, the RM6 can be fitted with a 260 or 520 mm raising plinth.

This addition, which simplifies civil engineering works, results in trenches of a smaller depth, or even in their complete elimination when the bending radius of the cables allows it.

The plinth is mounted directly on the floor.

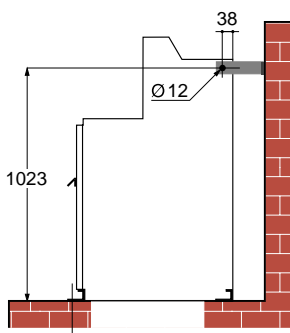

For connection to "network" or "transformer" via circuit breaker

The "network" cables can be run either:
 ■ through trenches, passages, ducts,
 ■ through the left or the right side.

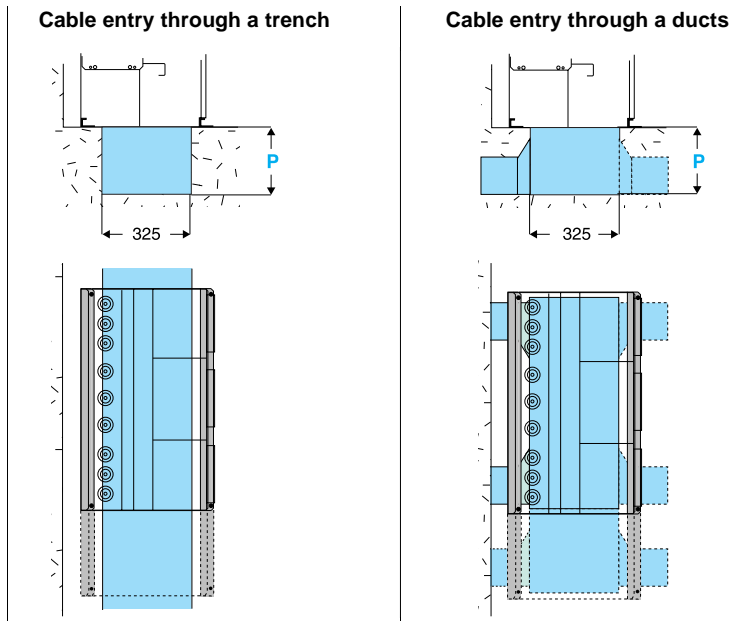

Trench depth P for RM6 without plinth

Note: trench depths can be reduced and sometimes eliminated by adding a plinth.

cable insulation	cable	cross-section (mm ²)	bending radius	plug-in P	disconnectable P	plug-in P	disconnectable P
dry insulation	single	≤ 150	500	400		400	
		185 to 300	600	520		520	
	three	≤ 150	550	660		660	
		185	650	770		770	
paper impregnated draining type	single	≤ 150	500		580		580
		185 to 300	675		800		800
	three	≤ 95	635		750		750
		150 to 300	835		970		970

For "transformer" connection via fuse-switch

The cross-sections of "transformer" cables are generally smaller than those of the "network" cables. All the cables are then run through the same space. When straight MV connectors are used, the depth P indicated below can be greater than that of the "network" cables.

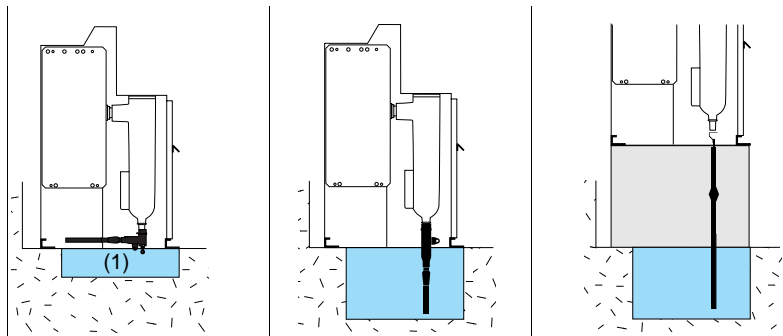

cable insulation	cable	cross-section (mm ²)	bending radius	plug-in elbow connector	plug-in straight connector	disconnectable (2) P
dry insulation	single	16 to 35	335	100	520	335
		50 to 70	400	100	520	440
		95 to 120	440	100	550	440
	three	35	435	100	520	725
		50 to 70	500	100	520	800
		95	545	100	550	860

(1) leave a clearance of 100 mm
 (2) 520 mm plinth must be used



Norway



Sweden



Spain



Russia



Australia

Main references

Asia / Middle East

- BSED, Bahrein
- DEWA, Dubaï
- WED, Abu Dhabi
- Tianjin Taifeng Industrial Park, China
- TNB, Malaysia
- China Steel Corporation, Taiwan
- TPC, Taiwan
- SCECO, Saudi Arabia

Africa

- Electricité de Mayotte
- EDF Reunion
- Total, Libya
- SONEI, Cameroon

South Amérique / Pacific

- CELESC, Santa Catarina, Brazil
- PETROBRAS, Rio de Janeiro, Brazil
- Guarulhos International Airport, Sao Paulo, Brazil
- CEMIG, Minas Gerais, Brazil

- EDF, French Guiana
- Tahiti Electricity
- Métro de Mexico, Mexico

Europe

- EDF, France
- Channel tunnel, France
- Iberdrola, Spain
- Compagnie Vaudoise d'électricité, SEIC, Switzerland
- Electrabel, Belgium
- Union Fenosa, Spain
- ENHER, Spain
- Oslo Energie, Norway
- STOEN, Poland
- Bayernwerke, Germany

Australasia

- Eau et Electricité de Calédonie, New-Caledonia
- Enercal, New-Caledonia
- United Energy, Australia

A major plus point

Merlin Gerin has integrated a functional organization into each of its units, the main purpose of which is to check quality and ensure the adherence to standards.

This procedure is:

- the same throughout the different departments,
- recognized by numerous approved customers and organizations.

Above all, it is our strict application of this functional organization that has enabled us to obtain the recognition of an independent organization, the French Association for Quality Assurance (Association Française pour l'Assurance Qualité, or **AFAQ**).

The RM6 design and production quality system has been certified as being in conformity with the requirements of the ISO 9001 and ISO 9002 quality assurance model.

**Rigorous, systematic checks**

During the manufacture of each RM6, it undergoes systematic **routine tests**, the aim of which is to check quality and conformity:

- tightness check
- filling pressure check
- opening and closing speed measurement
- operating torque measurement
- partial discharge check
- dielectric check
- conformity with drawings and diagrams.

The quality control department records and signs the results obtained on the **test certificate** for each device.

The Schneider recycling procedure for SF6 based products is subject to rigorous management, and allows each device to be traced through to its final destruction documentation.



Schneider Electric is committed to a long term environmental approach. As part of this, the SM6 range has been designed to be environmentally friendly, notably in terms of the product's recyclability. The materials used, both conductors and insulators, are identified and easily separable. At the end of its life, SM6 can be processed, recycled and its materials recovered in conformity with the draft European regulations on the end-of-life of electronic and electrical products, and in particular without any gas being released to the atmosphere nor any polluting fluids being discharged.

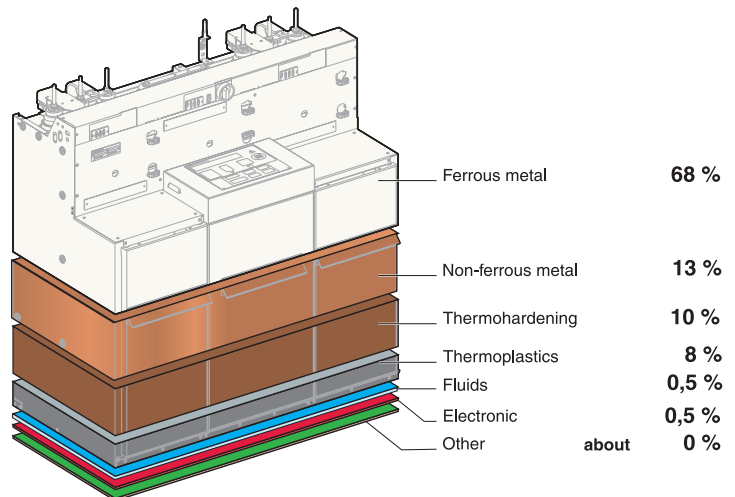

■ The environmental management system adopted by Schneider Electric production sites that produce the SM6 have been assessed and judged to be in conformity with requirements in the ISO14001 standard.

Only one of the boxes (ticked or filled) by the needed value) have to be considered between each horizontal line.

Blue box corresponds to none priced functions.

Basic unit characteristics

Rated voltage U_r (kV)

Short-circuit current I_{sc} (kA)

Time current of short-circuit 1 s 3 s

Rated current I_r (A)

Extension type NE RE DE

Possible functions choice

---	I	---	I
--	Q	--	Q
--	D	--	D
--	B	--	B
--	Q I	--	D
--	D I	--	B
--	I I		
-	I Q I	-	I Q I
I	I Q I	I	I Q I
Q	I Q I	Q	I Q I
-	I D I	-	I D I
I	I D I	I	I D I
D	I D I	D	I D I
-	I I I	-	I I I
I	I I I	I	I I I
T	I I I		
-	I B I	-	I B I
I	I B I	I	I B I
B	I B I	B	I B I

Specific option for one function

Bushing for I function

Plug in 400 A type B

Bolted M16 screw type C (compulsory with 17.5 or 24 kV-630 A)

Bolted 5/8" ANSI

Bushing for D function

Plug in 200 A type A (limited to 12.5 kA 1 s)

Plug in 400 A type B (limited to 16 kA 1 s)

Bolted M16 screw type C (compulsory with 17.5 or 24 kV-630 A)

Bushing well ANSI (limited to 12.5 kA 1 s)

Bushing for B function

Bolted M16 type C

Bolted 5/8" ANSI

Bushing for Q function

Plug in 200 A

Heat shinkable terminal for fuse chamber

Cable type for I function single core 3 core

Bottom plate in cable compartment (compulsory in case of 3 core cable)

Cable type for D or B function single core 3 core

Bottom plate in cable compartment (compulsory in case of 3 core cable)

In and fuse type for Q function (fuses to be procured separately)

6 kV 10 kV 12/24 kV & 10/100 A

16 to 100 A 125 A

Global option and accessories

Manometer without standard

Arabic Scandinavian

Lightening arrester on incoming functions (unable to coexist with internal arc cable box and only Elastimold)

Additional earth busbar in cable compartment (compulsory if earth fault > 6 kA 1s)

Raising plinth h = 260 mm h = 520 mm

Set of 3 MV fuses Fusarc CF rating (A)

Phase comparator

Test box for circuit breaker (VAP6)

Internal arc cable box 16 kA 1 s for I and D or B functions (unable to coexist with short-circuit indicator liquid type)

O and M manual language French English

Basic unit configuration

Switchboard →

	4th function	3rd only I function	2nd function	1st only I function
Configuration (one function per box)	<input type="checkbox"/>	<input type="checkbox"/>	<input type="checkbox"/>	<input type="checkbox"/>
Example →	-	-	D	I

Quantity

Switchboard option for I, D, B, Q functions

Auxiliary contacts alone

for main switch position indication 2 NO - 2 NC and ESw 1 O/C (this option is included in remote operation option)

<input type="checkbox"/>	<input type="checkbox"/>	<input type="checkbox"/>	<input type="checkbox"/>
--------------------------	--------------------------	--------------------------	--------------------------

Switchboard option for I function (Load-Break Switch "LBSw")

Arc short-circuiting device

<input type="checkbox"/>	<input type="checkbox"/>	<input type="checkbox"/>	<input type="checkbox"/>
--------------------------	--------------------------	--------------------------	--------------------------

Front door of cable connection compartment

Bolted

Removable with ESw interlocking

Removable with ESw interlocking and LBSw interlocking

Short-circuit indicator

Alpha M (for 4 I unit mini = 2)

Alpha E (for 4 I unit mini = 2)

Short-circuit current setting 400 A 600 A 800 A 1000 A

Front door with window (for checking of liquid type short-circuit indicator - not supplied)

Remote operation on I function

Motor mechanism and auxiliary contacts LBSw 2 NO - 2 NC and ESw 1 O/C

50 Hz 60 Hz

120 Vac 220 Vac

24 Vdc 48 Vdc 60 Vdc 110 Vdc 125 Vdc 220 Vdc

Switchboard option for D or B function (Circuit Breaker "CB")

Front door of cable connection compartment (only if this option is chosen with I function)

Bolted

Removable with ESw interlocking

Removable with ESw interlocking and CB interlocking

Protection relay for CB transformer protection (only one VIP type per unit)

Relay VIP30 (over current)

Relay VIP35 (over current and earth fault)

Relay VIP300 (over current & earth fault/ multi curve in accordance with IEC 255-3)

Forbidden closing under fault 1NC

Auxiliary Contact D or B tripping

Shunt trip coil for external tripping

50 Hz 60 Hz

120 Vac 220 Vac

24 Vdc 48 Vdc 60 Vdc 110 Vdc 125 Vdc 220 Vdc

Remote operation on D or B function

Motor mechanism and auxiliary contacts CB 2 NO - 2 NC and ESw 1 O/C (including shunt trip coil)

50 Hz 60 Hz

120 Vac 220 Vac

24 Vdc 48 Vdc 60 Vdc 110 Vdc 125 Vdc 220 Vdc

Switchboard option for Q function (fuse combination)

Auxiliary contact for fuses blown

Shunt trip coil for external tripping

50 Hz 60 Hz

120 Vac 220 Vac

24 Vdc 48 Vdc 60 Vdc 110 Vdc 125 Vdc 220 Vdc

Switchboard option for operation

Voltage indicator VPIS VDS

Network service voltage 3.2/7.2 kV 10/24 kV

Key locking devices Ronis Profalux

Type R1 (on I and B functions)

on switch or CB on earth switch

Type R2 (on I and B functions)

Type R6 (on Q or D functions)

Type R7 (on Q or D functions)

Type R8 (on Q or D functions)

Notes

Notes

Schneider Electric Industries SA

Postal address
MV department
F-38050 Grenoble Cedex 9
Tel. : +33 (0)4 76 57 60 60
<http://www.schneider-electric.com>

Due to the changes in standards and equipment, the characteristics given in the text and images of this document can only be considered as binding after confirmation by the relevant departments in our company.



*This document has been
printed on ecological paper.*

Publishing : Schneider Electric SA
Design : HeadLines
Printing : Imprimerie des Deux - Ponts